

**Caution: This document contains mixed page sizes (8.5 x 11 or 11 x 17), which may affect printing. Please adjust your printer settings according to the size of each page you wish to print.**



Redistribution or publication of this document by any means, is strictly prohibited.

**Onan**

***RV GenSet***

**Installation Manual**

**HDKAL, HDKAQ, HDKAR Generator Sets**



Printed in U.S.A.

981-0612  
10-97

## **California**

### **Proposition 65 Warning**

**Diesel engine exhaust and some of its constituents are known to the State of California to cause cancer, birth defects, and other reproductive harm.**

# Table of Contents

---

	<b>SAFETY PRECAUTIONS</b> .....	ii
<b>1</b>	<b>INTRODUCTION</b> .....	1-1
	Installation Codes and Safety Recommendations .....	1-1
<b>2</b>	<b>SPECIFICATIONS</b> .....	2-1
<b>3</b>	<b>INSTALLATION OUTLINE</b> .....	3-1
	Introduction .....	3-1
	Preparation .....	3-1
	Compartment Mounting .....	3-1
	Connecting to Vehicle Systems .....	3-2
	Exhaust Systems .....	3-2
<b>4</b>	<b>MOUNTING</b> .....	4-1
	Location .....	4-1
	Mounting Principles .....	4-1
<b>5</b>	<b>VENTILATION AND ACOUSTICS</b> .....	5-1
<b>6</b>	<b>EXHAUST SYSTEM</b> .....	6-1
	General .....	6-1
	Muffler Recommendations .....	6-1
	Exhaust Installation Guidelines .....	6-1
	Tailpipe Recommendations .....	6-2
<b>7</b>	<b>COOLING SYSTEM</b> .....	7-1
	Coolant Recovery Tank .....	7-1
<b>8</b>	<b>FUEL SYSTEM</b> .....	8-1
	General .....	8-1
	Fuel System .....	8-1
<b>9</b>	<b>ELECTRICAL CONNECTIONS</b> .....	9-1
	General .....	9-1
	Conduit .....	9-1
	Wiring Disconnect .....	9-2
	Line Circuit Breakers .....	9-2
	Load Connections .....	9-2
	Remote Control Connections .....	9-4
	Starting Battery .....	9-4
	Remote Installation of Genset Control Box .....	9-5
<b>10</b>	<b>INITIAL START AND CHECKS</b> .....	10-1
	Installation Review .....	10-1
	Initial Starting and Checks .....	10-3
<b>11</b>	<b>WIRING DIAGRAMS</b> .....	11-1

# Safety Precautions

---

Thoroughly read the **OPERATOR'S MANUAL** before operating the genset. Safe operation and top performance can be obtained only with proper operation and maintenance.

The following symbols in this Manual alert you to potential hazards to the operator, service person and equipment.

**⚠ DANGER** Alerts you to an immediate hazard which will result in severe personal injury or death.

**⚠ WARNING** Alerts you to a hazard or unsafe practice which can result in severe personal injury or death.

**⚠ CAUTION** Alerts you to a hazard or unsafe practice which can result in personal injury or equipment damage.

Electricity, fuel, exhaust, moving parts and batteries present hazards which can result in severe personal injury or death.

## GENERAL PRECAUTIONS

- Keep ABC fire extinguishers handy.
- Make sure all fasteners are secure and torqued properly.
- Keep the genset and its compartment clean. Excess oil and oily rags can catch fire. Dirt and gear stowed in the compartment can restrict cooling air.
- Before working on the genset, disconnect the negative (-) battery cable at the battery to prevent starting.
- Use caution when making adjustments while the genset is running—hot, moving or electrically live parts can cause severe personal injury or death.
- Used engine oil has been identified by some state and federal agencies as causing cancer or

reproductive toxicity. Do not ingest, inhale, or contact used oil or its vapors.

- Benzene and lead in some gasolines have been identified by some state and federal agencies as causing cancer or reproductive toxicity. Do not ingest, inhale or contact gasoline or its vapors.
- Do not work on the genset when mentally or physically fatigued or after consuming alcohol or drugs.
- Carefully follow all applicable local, state and federal codes.

## GENERATOR VOLTAGE IS DEADLY!

- Generator output connections must be made by a qualified electrician in accordance with applicable codes.
- The genset must not be connected to the public utility or any other source of electrical power. Connection could lead to electrocution of utility workers, damage to equipment and fire. An approved switching device must be used to prevent interconnections.
- Use caution when working on live electrical equipment. Remove jewelry, make sure clothing and shoes are dry and stand on a dry wooden platform on the ground or floor.

## FUEL IS FLAMMABLE AND EXPLOSIVE

- Keep flames, cigarettes, sparks, pilot lights, electrical arc-producing equipment and switches and all other sources of ignition well away from areas where fuel fumes are present and areas sharing ventilation.
- Fuel lines must be secured, free of leaks and separated or shielded from electrical wiring.
- Use approved non-conductive flexible fuel hose for fuel connections at the genset.

## ENGINE EXHAUST IS DEADLY!

- Learn the symptoms of carbon monoxide poisoning in this Manual.
- Never sleep in the vehicle while the genset is running unless the vehicle has a working carbon monoxide detector.
- The exhaust system must be installed in accordance with the genset Installation Manual.
- Do not use engine cooling air to heat the vehicle interior.
- Make sure there is ample fresh air when operating the genset in a confined area.

## MOVING PARTS CAN CAUSE SEVERE PERSONAL INJURY OR DEATH

- Do not wear loose clothing or jewelry near moving parts such as PTO shafts, fans, belts and pulleys.
- Keep hands away from moving parts.
- Keep guards in place over fans, belts, pulleys, etc.

## BATTERY GAS IS EXPLOSIVE

- Wear safety glasses and do not smoke while servicing batteries.
- When disconnecting or reconnecting battery cables, always disconnect the negative (-) battery cable first and reconnect it last to reduce arcing.

## DO NOT OPERATE IN FLAMMABLE AND EXPLOSIVE ENVIRONMENTS

Flammable vapor can cause a diesel engine to overspeed and become difficult to stop, resulting in possible fire, explosion, severe personal injury and death. ***Do not operate a diesel-powered genset where a flammable vapor environment can be created by fuel spill, leak, etc., unless the genset is equipped with an automatic safety device to block the air intake and stop the engine.*** The owners and operators of the genset are the ones solely responsible for operating the genset safely. Contact your authorized Onan/Cummins dealer or distributor for more information.

Mobile-3

# 1. Introduction

---

This manual shows how to install the HDKAL/HDKAQ/HDKAR diesel generator set. The genset must be installed properly to operate reliably, quietly, and safely. **Read the entire manual before starting installation.**

See the Operator's Manual (981-0148) for operation and maintenance instructions.

The following subjects are covered in this manual. Consider **all** these requirements before installing the set.

- Level and supportive mounting surface
- Adequate cooling air inlet
- Adequate fresh induction air
- Discharge of cooling air
- Noise levels
- Accessibility for maintenance and service
- Exhaust connections
- Fuel supply
- Electrical connections

## INSTALLATION CODES AND SAFETY RECOMMENDATIONS

When properly installed, this generator set meets or exceeds these codes:

- National Electrical Code, NFPA 70-Article 551
- ANSI/RVIA EGS-1, Engine Generator Sets
- ANSI A119.2/NFPA 501C Standard for Recreational Vehicles

The vehicle builder and/or the generator set installer must comply with all local codes that apply to generator set installation. The generator set installer bears sole responsibility for the selection of the

appropriate generator set, installation design, and installation.

The following Installation Codes and Safety Recommendations apply to the installation and operation of generator sets in RVs and in commercial vehicles. The address of each agency is listed so that copies of the codes may be obtained. Installation codes and recommendations are subject to change, and may vary by location or over time. **The vehicle manufacturer and the genset installer bear sole responsibility for following all applicable codes and regulations.**

- |   |  |
|---|--|
| 1. ANSI-A119.2<br>FMVSS 301                                     | Recreational Vehicle<br>Industry Association<br>14650 Lee Road<br>Chantilly, VA 22021                |
| 2. NFPA 70 (N.E.C.)<br>NFPA-501C                                | National Fire Protection<br>Association<br>470 Atlantic Avenue<br>Boston, MA 02210                   |
| 3. California<br>Administrative<br>Code - Title 25<br>Chapter 3 | State of California<br>Documents Section<br>P.O. Box 1015<br>North Highlands, CA<br>95660            |
| 4. U.S. Forest<br>Service<br>5100-1A                            | Eastern Region 9<br>USDA Forest Service<br>310 W. Wisconsin Ave.<br>Room 500<br>Milwaukee, WI, 53203 |

**This manual contains information that is subject to change. For this reason, use only the installation manual supplied with the generator set for the installation.**

**⚠️WARNING** *Incorrect installation, service, or replacement of parts can result in severe personal injury, death and/or equipment damage. Service personnel must be qualified to perform electrical and/or mechanical component installation.*

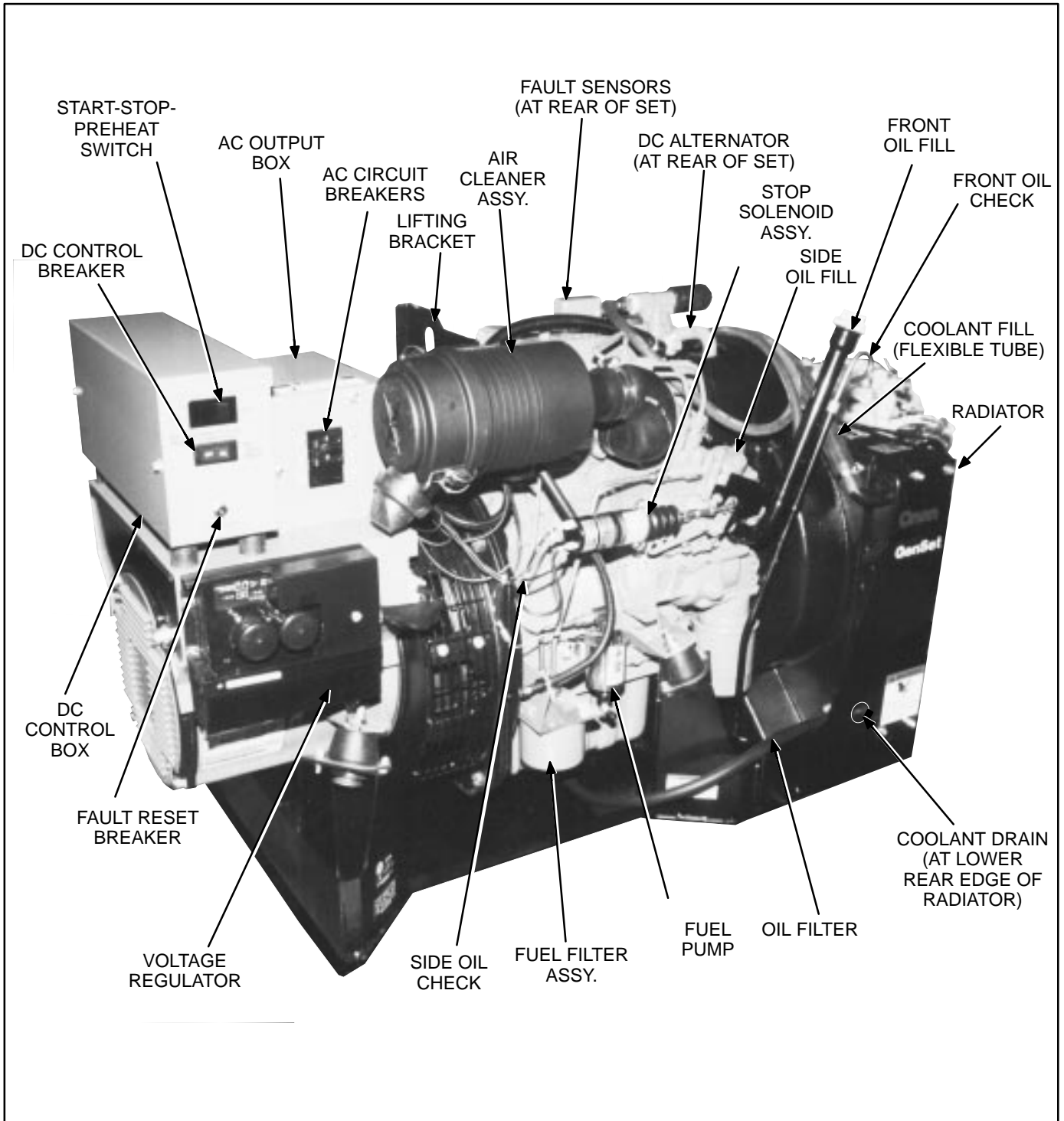

**FIGURE 1-1. HDKAL/HDKAQ/HDKAR GENERATOR SET**



# 2. Specifications

## Control System

- Unit Mounted, Drip-Proof, Vibration Isolated Console
- **DC Controls - 12-Volt System**
  - Start/Stop/Preheat Switch
  - Sealed Remote Connector for Start/Stop/Preheat Switch Gauge Package
  - Manual Reset Fault Relay Indicating Engine Shutdown for High Coolant Temperature, Low Oil Pressure
- **AC Controls**
  - Voltage Regulator (See Generator Detail)
  - One 35-amp, 2 pole Circuit Breaker - 60 Hz

## Engine Detail

**Design:** 3-Cycle, Liquid-cooled Diesel Engine  
**Cylinders:** Inline Vertical - 3  
**Bore:**  
 HDKAL/HDKAQ 2.99-in (76 mm)  
 HDKAR 2.83 IN (72 MM)  
**Stroke:** 2.90-in (73.6 mm)  
**Displacement**  
 HDKAL/HDKAQ 61.08in<sup>3</sup> (1001 cm<sup>3</sup>)  
 HDKAR 54.8 in<sup>3</sup> (898 cm<sup>3</sup>)  
**Compression Ratio:** 23 to 1  
**Lube Oil Capacity:** 4.5 qt (4.25 L) Including Filter  
**Cooling System Capacity:** 1.25 gal (4.73 L)  
**Engine Power (max) at 1800 r/min:**  
 HDKAL/HDKAQ 13.1 bhp  
 HDKAR 11.9 bhp

**Starting System:** Remote, 12-volt  
**Fuel Injection Pump:** Bosch K mini  
**Combustion Chamber:** Spherical  
**Fuel Consumption:** No. 2 Diesel Fuel, gph/lph

	No Load	Half Load	Full Load
HDKAL	0.26 gph 0.98 lph	0.49 gph 1.85 lph	0.85 gph 3.2 lph
HDKAQ	0.25 gph 0.95 lph	0.56 gph 1.93 lph	0.9 gph 3.41 lph
HDKAR	0.23 gph 0.87 lph	0.46 gph 1.74 lph	0.8 gph 3.03 lph

## Generator Detail

**Design:** Onan, Brush type, Drip-proof Construction.  
**Insulation System Rise:** Class F per NEMA  
 MGI-1.65 and BS 2757 Insulating Varnish Conforms to MIL-1-24092, Grade CB, Class 155 C.

**Exciter System:** Electronic Voltage Regulator  
**Bearing:** Double Sealed Prelubricated Ball Bearing  
**Cooling:** Direct Drive Centrifugal Blower

## GenSet Performance

**Regulation, No Load to Rated Load**  
**Voltage:**  $\pm 2.5\%$  (single-phase)  
**Frequency:**  $\pm 2.5\%$   
**Battery Charging:** 12-Volt Battery Charging DC Alternator (30 amp output)  
**Sound Level:** 78 dB(a) @ 3 m rated load  
**Random Frequency Variation** for Constant Loads

from No Load to Full Load is  $\pm 1\%$   
**Random Voltage Variation:** Under These Conditions is  $\pm 1\%$  for Single-Phase  
**Maximum Operating Ambient Temperature:** Efficient Radiator Cooling System Permits Operation at Ambient Temperatures up to 120°F (49°C).

## Accessories

- Required Accessory**
- (USDA Forest Service Approved Spark Arrester Muffler.
  - Exhaust Resonator
- Optional Accessories**
- Battery - 12 volt, 475 Cold Cranking Amps at 0°F (-17.8°C)
  - Remote Gauge Package with Start/Stop/Preheat Switch, Voltage Meter, Water Temperature Gauge, Oil Pressure Gauge, Running Time Meter
  - Remote Circuit Breaker Kit 35 Amp, 2 Pole
  - Remote Wiring Harness, 15 or 25 ft.
  - Coolant Recovery Kit

Blank Page

# 3. Installation Outline

---

## INTRODUCTION

This section describes the steps in a typical compartment-mount installation. The installer is responsible for complying with all applicable installation codes and safety requirements. This section includes:

- Preparation
- Compartment Mounting
- Connecting to Vehicle Systems
- Exhaust System

Refer to the detailed instructions that are given in each section, covering mounting, ventilation, fuel system, electrical connections, and exhaust system, for specific procedures and important safety precautions.

## PREPARATION

1. Remove the wooden shipping crate by prying the bottom of the crate's sides and ends out from the wooden skid base. Carefully lift the crate off the genset and discard.
2. Remove the plastic bag covering the genset. Collect loose shipped items, such as the Operator's Manual, and add them to the vehicle documentation package.
3. Remove the mounting nuts and bolts that secure the wooden skid to the genset base. Lift the set off the skid.

## COMPARTMENT MOUNTING

Install the generator set in a compartment of its own. If any part of the compartment is above the vehicle floor, separate the compartment from the living quarters with vapor-tight walls. Refer to the *Mounting* section for compartment construction details.

**⚠WARNING** *Exhaust gases present the hazard of severe personal injury or death. Make the compartment walls vapor tight to the interior of the vehicle to prevent exhaust fumes from entering the living quarters.*

1. The generator set requires unobstructed cooling air inlets for the generator and radiator. Refer to the *Mounting* and *Ventilation* section for details.
2. Provide access to the set for maintenance.
3. Provide space for removing the set either through the door or out the bottom of the compartment.
4. Carefully measure the compartment to provide proper clearance for the generator set. Allow extra space for insulation clearance. (Refer to *Mounting* [section 4] for details).
5. Make holes in the bottom of the compartment for genset mounting, air outlet and oil drain (Figure 4-2). If there is wood under the compartment, remove the section under the compartment and replace it with a sheet metal floor and an adequate steel support frame.
6. Put holes in the compartment to run connections for the fuel line, battery cable, remote control harness and AC conduit. Design holes so they will not chafe or restrict the lines. (Refer to sections 8 and 9 for details).

Make sure wires and lines are protected from hot, sharp and abrasive surfaces and are not kinked.

7. Position the generator set in the compartment and bolt in place.

---

## CONNECTING TO VEHICLE SYSTEMS

1. Route fuel line separate from electrical wires or separate them with conduit or other sheathing.

**⚠WARNING** *Fuel presents the hazard of fire or explosion that can result in severe personal injury or death. Do not smoke or allow any cigarette flame, spark, pilot light, arc-producing equipment or switch on other ignition sources near fuel or in the installation area or area sharing ventilation. Read the important safety precautions in the Fuel Systems section.*

2. Connect fuel supply and return lines per Section 8.
3. Install a listed flexible water-tight conduit over the AC wiring. Secure the conduit to the fitting on the generator set.

**⚠WARNING** *Accidental starting of the genset can cause severe personal injury or death. Do not connect the battery cables to the genset starting battery until instructed to in the Initial Start and Checks section.*

4. Route the remote control connector through an opening in the compartment. Connect the remote control connector to the mating connector on the DC control box.
5. Route the battery positive (+) cable through an access hole in the compartment. Connect the battery positive (+) cable to the B+ connection on the start solenoid at the starter.
6. Connect the battery negative (-) cable to the labeled hole in the engine block with other ground connections.

## EXHAUST SYSTEMS

**⚠WARNING** *Exhaust gas presents the hazard of severe personal injury or death. Exhaust pipe must be supported at the vehicle perimeter and extends one inch beyond perimeter. The exhaust pipe must not terminate in departure angle so that any vent, window, or opening into the living area is within the area. Read the important safety precautions in the Exhaust Systems section.*

1. Connect the exhaust pipe (installer-supplied) to the genset.
2. Do not terminate the exhaust tail pipe under the vehicle. The exhaust tail pipe must terminate 1 inch (25.4 mm) beyond the side or end of the vehicle.
3. Support the tail pipe as close to the outside of the vehicle as possible.
4. Termination of the exhaust tail pipe below the angle of departure (lowest point on rear of vehicle to the tire ground contact point) must be protected by a skid bar, trailer hitch, or some frame member.

**⚠WARNING** *Tailpipe must not be in the angle of departure. If tailpipe is accidentally bent or crushed, exhaust gases might not be able to escape, and may be drawn into the living quarters of the vehicle, causing severe personal injury or death.*

5. Be aware that any vent, window, or opening that can be opened and that is not permanently sealed from the vehicle living space or work area, can be an avenue for carbon monoxide.

The tail pipe must not terminate so that any vent, window, or opening into the living area is within the shaded area.

# 4. Mounting

## LOCATION

The genset location must be well ventilated, insulated, close to the fuel supply and close to the center of electrical load distribution.

Select a location that will allow adequate space on all sides for ventilation and servicing the set. On RV installations, keep the genset away from living quarters.

## MOUNTING PRINCIPLES

The genset is designed for either compartment or front of vehicle mounting. The vehicle frame must support the weight of the generator set (approximately 490 pounds (plus forces of vibration)).

Carefully follow these design parameters when developing the genset support structure:

- The dynamic conditions imposed on the set should not exceed cyclic vertical forces of  $\pm 1500$  lbs ( $\pm 3$  g-force) and cyclic horizontal forces of  $\pm 500$  lbs ( $\pm 1$  g-force).
- The mounting surface of the vehicle support structure must be flat and must be able to support the housing in such a way that mounting fasteners, when properly torqued, do not imbed or compress the mounting surface.
- All fasteners used in the installation must be properly torqued according to the installation instructions.

Mounting hole locations are shown in Figure 4-2. Install two bolts and flat washers to the bottom of the drip pan on both sides of the genset. Tighten the bolts securely to the mounting base.

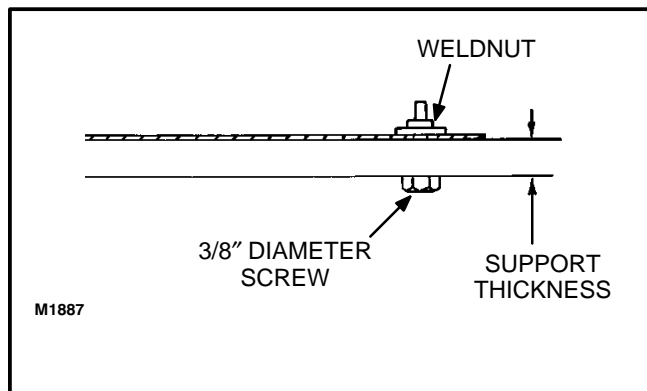

FIGURE 4-1. COMPARTMENT MOUNTING

The mounting support structure must not obstruct cooling air flow and serviceability. See Figure 4-2 for compartment floor layout.

Construct the genset compartment according to Installation Codes and Safety Recommendations listed in Section 1 of this manual. Figure 4-3 shows genset dimensions.

There is one inch (25 mm) minimum clearance between the set and compartment insulation. Minimum space between the engine exhaust components and compartment insulation is 3 inches (76 mm).

When constructing the genset compartment, allow for airflow restrictions caused by duct work and grilles. To purge the compartment of hot air, the air openings position must permit airflow while the set is running. On shutdown, the openings must allow hot air to escape the compartment.

Make the access opening large enough to remove the set, with openings at the ends of the compartment for engine and generator cooling air. An engine fan and a generator fan cool the set. The engine fan pulls air through the radiator. A centrifugal blower mounted on the generator drive disc draws generator cooling air into the end bell and discharges it at the blower outlet. See the *Ventilation* section of this manual for more details.

Allow clearance to ensure access to maintain or operate the following components:

- Oil fill
- Oil drain
- Oil filter
- Oil dipstick
- Air cleaner
- Start/Stop switch
- AC circuit breaker
- DC control breaker
- DC fault breaker
- Coolant drain
- Coolant fill

Mount the coolant recovery tank (optional accessory package) so coolant can be added easily. Hoses are connected similarly, as shown in Figure 7-2.

---

## Compartment Construction

1. Construct a vapor-tight wall to separate the compartment area from the living quarters or work area and the fuel supply. See Figure 4-2 for minimum compartment dimensions.
2. Line the compartment walls with 26-gauge galvanized steel or a material of comparable strength and fire resistance (see NFPA 70, NEC and California Title 25 for complete details).

**⚠WARNING** *Exhaust gases present the hazard of severe personal injury or death. Make the compartment walls vapor-tight to the interior of the vehicle to prevent exhaust fumes from entering.*

3. Construct the compartment floor to allow exhaust and cooling air to exit and to prevent oil, fuel or water from accumulating. Figure 4-2 shows the layout of the compartment floor.

**⚠WARNING** *Fuel and oil leakage is a fire hazard that can cause serious personal injury or death. Do not position the muffler directly below the drain hole.*

Do NOT use absorbent soundproofing material on the compartment floor as it can absorb flammable oil and fuel.

The floor should have as few openings as possible, to reduce the noise level.

4. Make holes or other provisions for diesel fuel supply and return lines to the compartment, and for the exhaust plumbing. See the *Fuel*

*System and Exhaust System* sections of this manual for guidance and code references.

5. Install an approved junction box for connecting generator and load leads. See the *Electrical* section of manual for guidance and code references.

If the compartment penetrates the vehicle floor, be sure all joints and corners of the compartment are vapor-tight to the interior. Seal all joints and bolts to prevent entrance of exhaust gas.

**⚠WARNING** *Exhaust gases are deadly. Inhalation of exhaust gas can result in severe personal injury or death. Be sure the compartment is sealed tightly to prevent entrance of deadly exhaust gas into the vehicle coach.*

To minimize noise, line the entire genset compartment (except the compartment floor) with a 1/2 to 1 inch (12.7 to 25.4 mm) thickness of self-extinguishing acoustical material, rated for 250° F (121° C) minimum. Adjust the compartment height, width and depth dimensions to fit the acoustical material.

A combination of materials works better than a single material to reduce noise. For example, composite materials are more effective than foam alone. Insulation must not reduce the minimum clearances specified in Figure 4-2, to meet ANSI and CSA insulation temperature rise limits for recreational vehicles.

**⚠WARNING** *Hot engine parts can ignite some insulation materials if too close, resulting in fire which can cause severe personal injury or death. Insulation must not reduce the specified minimum clearances.*

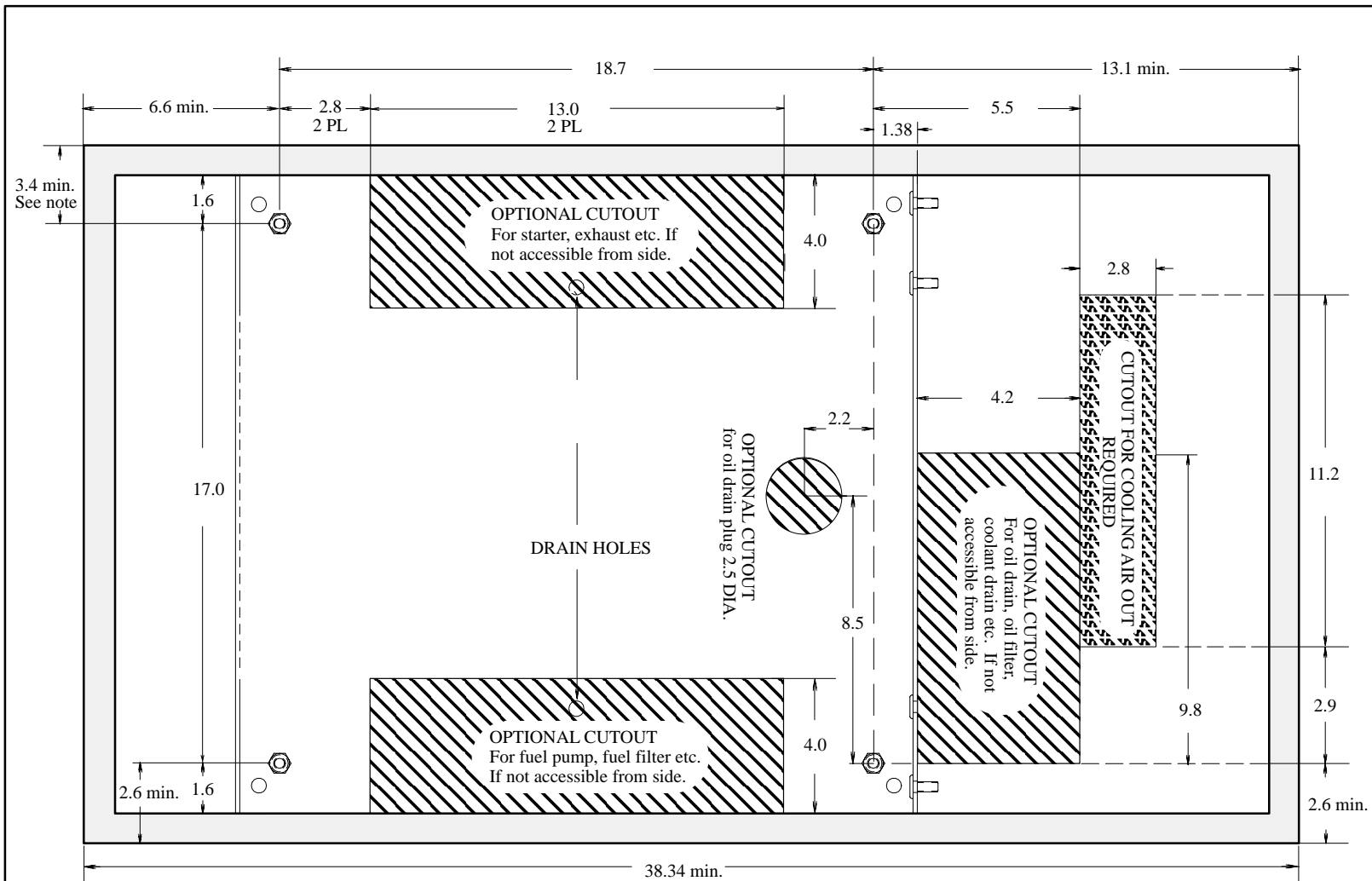

FIGURE 4-2. COMPARTMENT FLOOR LAYOUT



NOTES:

All dimensions in inches.

3.4 inches is the minimum dimension to the compartment wall along this side except around exhaust components. 3 inch minimum clearance is required between hot exhaust components and any combustible materials.

-  ONE INCH MINIMUM CLEARANCE
-  OPTIONAL CUTOUTS
-  REQUIRED CUTOUTS



**Clearances (approximate):**

- Wall to drip pan (service side of set): 1 inch
- Clearance, wall to exhaust elbow (rear of set): 3 inches
- Clearance at top of set: 1 inch

**Compartment dimensions (approximate):**

- Height: 25 inches
- Depth: 25 inches
- Width: 38.4 inches

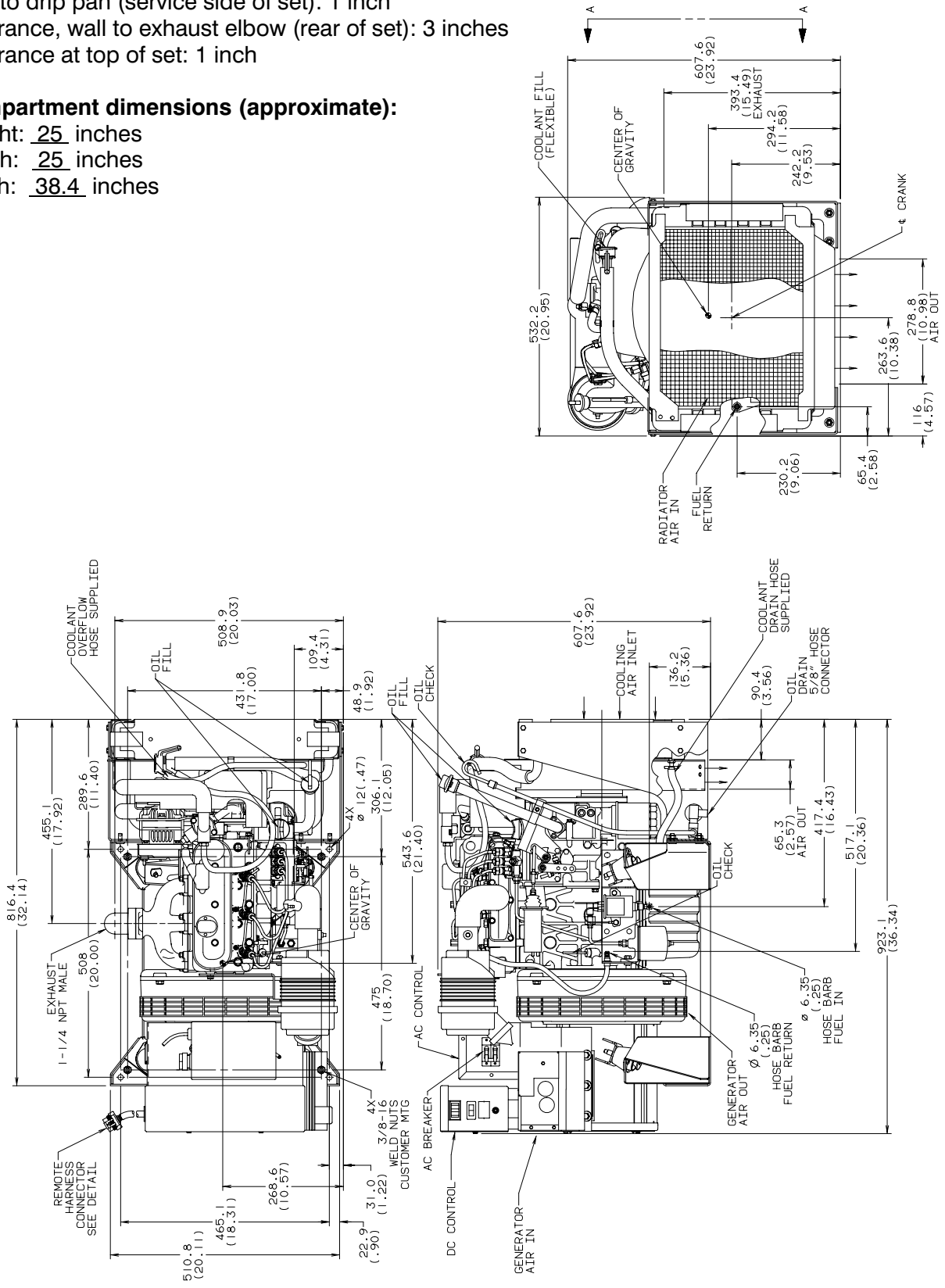

**FIGURE 4-3. HDKAL/HDKAQ/HDKAR MOUNTING DIMENSIONS (from 500-3098)**



## Slide-Out Mounting

An alternative mounting scheme is to mount the generator set in a “drawer” configuration, so that it may be slid in and out of the vehicle. Figure 4-4 illustrates such an installation. The genset drip pan is bolted to two sliding drawer channels, which support its weight and dynamic loading. The set is locked into position inside the vehicle when it is operated. When service is necessary, the set slides out of the vehicle, for easy access to both sides.

Note that when the generator set is installed in a slide-out mechanism, it is important to make sure all

connections (fuel, AC leads, remote control, and exhaust) have slack or methods of absorbing the movements.

**⚠WARNING** *Hot exhaust parts can cause severe burns. Make certain that the muffler and exhaust are adequately shielded from contact.*

More information on alternative mounting schemes may be obtained from the Onan distributor or factory. However, the Onan Corporation does not provide slide-mounting hardware for the HDKAL/HDKAQ/HDKAR generator set.

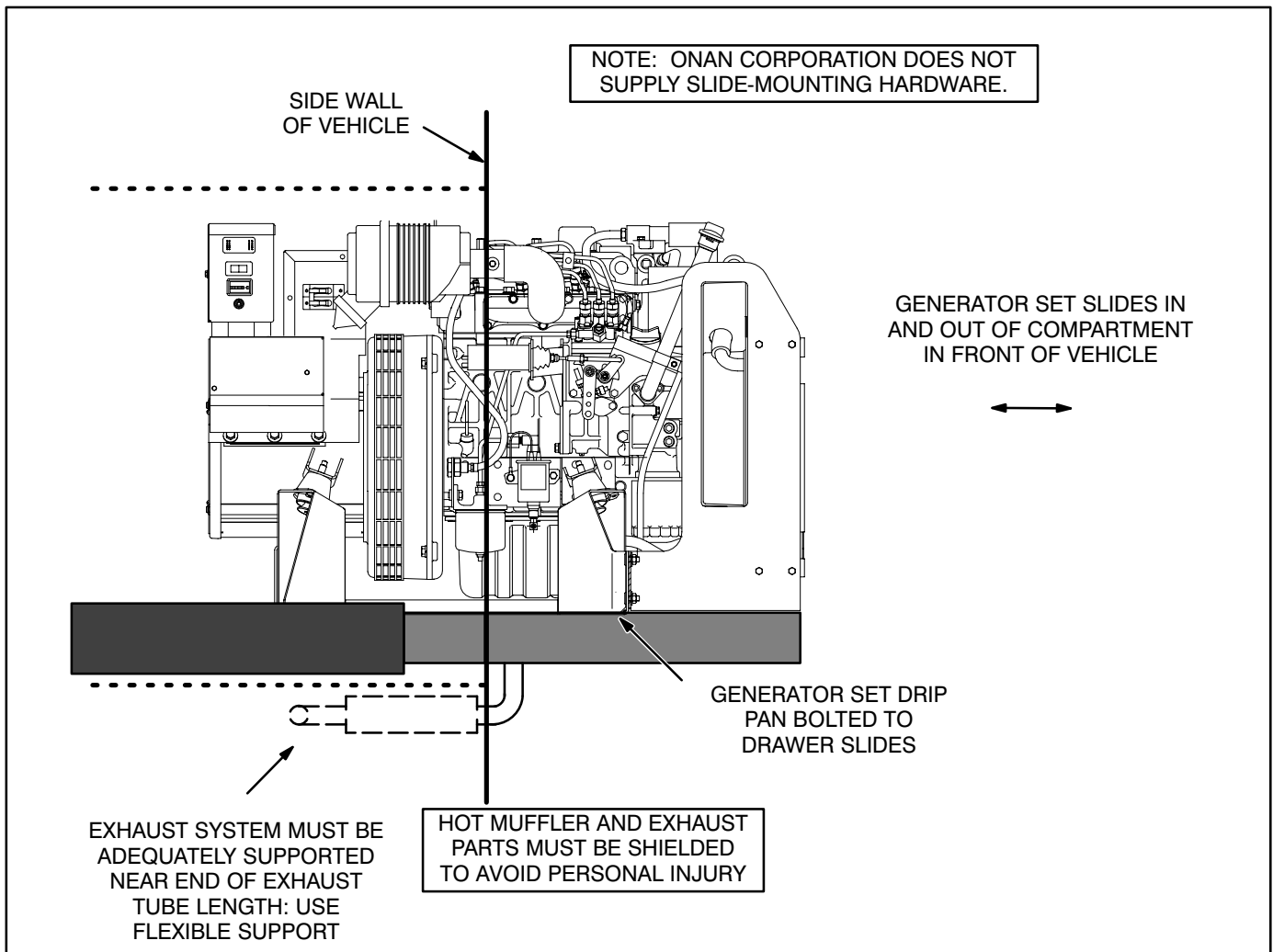
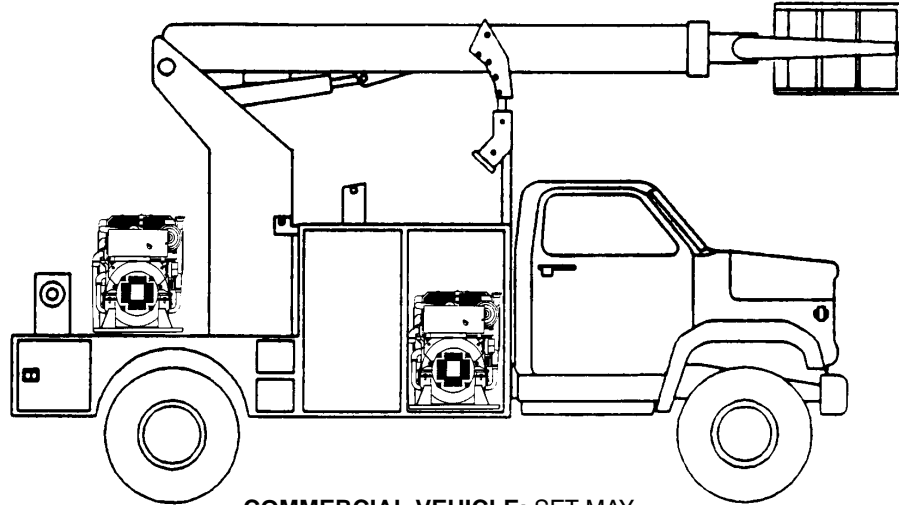
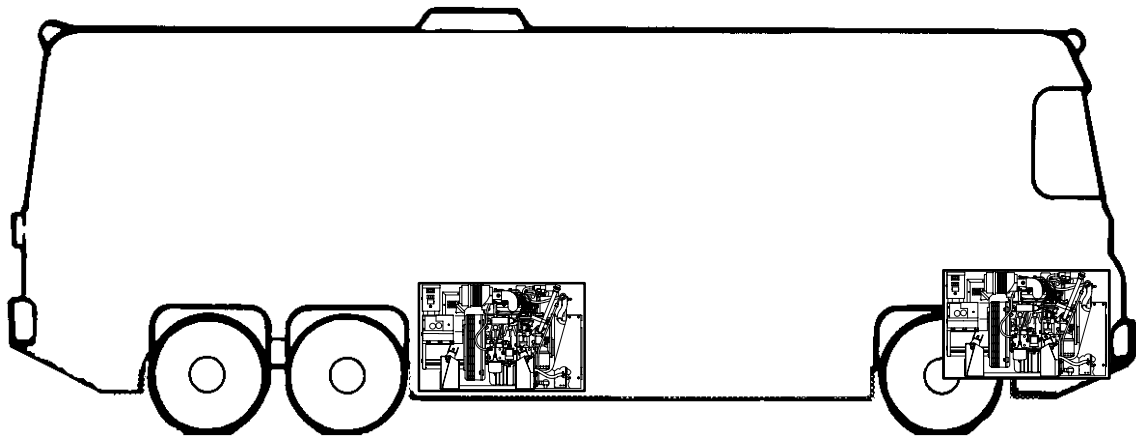

FIGURE 4-4. GENSET IN SLIDE-MOUNTED CONFIGURATION



**COMMERCIAL VEHICLE:** SET MAY BE MOUNTED ON TRUCK BED OR IN COMPARTMENT WITH MINIMAL SOUNDPROOFING



**RECREATIONAL VEHICLE:** SET SHOULD BE MOUNTED IN SOUNDPROOF COMPARTMENT IN SIDE OF RV. ALTERNATIVE MOUNTING: SLIDE-OUT OR PERMANENT INSTALLATION IN NOSE OF RV.

**FIGURE 4-5. SUGGESTED MOUNTING LOCATIONS IN COMMERCIAL AND RECREATIONAL VEHICLES**

# 5. Ventilation and Acoustics

The most important factors of ventilation for radiator-cooled mobile gensets are:

- Sufficient incoming cooling air
- Adequate exhausting of heated air

The HDKAL, HDKAQ, and HDKAR is supplied with a suction-type fan. The cooling air is discharged out the bottom of the generator set.

**▲WARNING** *Never use discharged cooling air for heating since it may contain poisonous gases. Inhalation of exhaust gases can result in severe personal injury or death.*

Cooling air requirements for Onan generator sets vary with type and size. Since the discharge area cannot be changed, the air inlet and outlet openings are critical. Be sure nothing obstructs or restricts discharged airflow.

The installation must provide an opening in the compartment floor to match the cooling duct as shown in Figure 4-2.

Cooling air requirements are:

- Radiator - 200 in<sup>2</sup>
- Generator Inlet - 100 in<sup>2</sup>

The HDKAL, HDKAQ, and HDKAR generator set is designed for front vehicle mounting or other locations where free air movement is not restricted. Contact the Onan distributor or factory for help on special installation considerations.

An expanded metal grille can be used over the inlet and outlet. However, when using this material, the area must be increased to compensate for the partial blockage caused by the material in the grille. The effective area of expanded material is typically 50 - 80 percent. For your material, contact the grille manufacturer.

**▲WARNING** *Leakage of fuel in or around the compartment can cause an explosion or fire resulting in severe personal injury or death. The ventilation system must provide a constant flow of air to expel any accumulation of fuel vapor. Compartments must be vapor-tight to the vehicle interior to keep fumes from entering.*

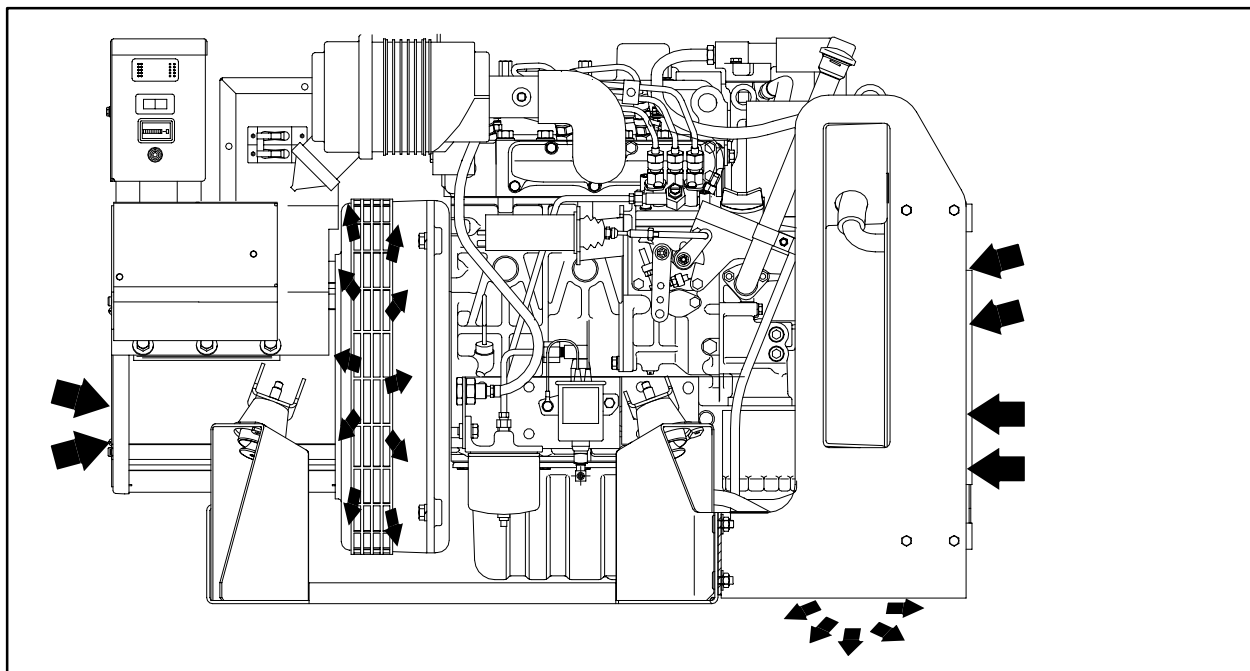

FIGURE 5-1. GENERATOR AND ENGINE COOLING AIRFLOW

# 6. Exhaust System

---

## GENERAL

Plan the exhaust system carefully. A vapor-tight, well-executed installation allows the genset to be operated quietly and safely. The exhaust system installation must comply with all applicable standards, local codes and regulations. Study the following recommendations.

## MUFFLER RECOMMENDATIONS

If the Onan RV genset was supplied without a muffler, we recommend the purchase of an Onan RV spark arresting muffler that Onan has constructed to meet RVIA and USDA standards for your RV genset.

The RVIA/ANSI EGS-1 standard requires that the muffler must be constructed of aluminized steel or other corrosion resistant material, and it must be of a welded or crimped construction.

A USDA approved spark arrestor that is designed for use with the muffler must be installed. The spark arrestor may be an integral part of the muffler or it may be an add-on type. Failure to use and maintain a spark arresting exhaust system is illegal on federally-owned lands, and could cause brush or forest fires.

The Onan spark arrester muffler is U.S. Forest Service-approved. Failure to provide and maintain a spark arrester can be a violation of U. S. Forest Service 5100-1a.

Liability for damage or injury, and warranty expenses due to use of unapproved mufflers or installation modifications becomes the responsibility of the person installing the substitute muffler or performing the modifications. Contact an Onan distributor or dealer for approved exhaust system parts.

## EXHAUST INSTALLATION GUIDELINES

The exhaust system must be located no closer than 3 inches (76 mm) from combustible material (wood,

felt, cotton, organic fibers, etc.). It must be located, insulated or shielded that it does not raise the temperature of any combustible material more than 149° F (65° C) above the ambient air inlet temperature.

The exhaust system must extend a minimum 1 inch (25 mm) beyond the perimeter of the vehicle. Do not terminate the exhaust tailpipe under the vehicle. Be aware that any vent, window, storage compartment or opening that can be opened and that is not permanently sealed from the vehicle living space can be an avenue for carbon monoxide to enter the vehicle. The tailpipe must not terminate so that any vent, window, or opening into the living area is within the circular area shown in Figure 6-4. This area is defined as a circle with a radius of six inches (152.4 mm) measured from the outside of the tailpipe.

**▲WARNING** *Exhaust gas is deadly and presents the hazard of severe personal injury or death. Do not terminate an exhaust pipe under the vehicle. The tailpipe must not terminate so that any vent, window, or opening into the living area is within the circular area shown in Figure 6-4. Keep all openings closed when the generator set is running.*

To reduce the chance of damaging the tailpipe and emitting exhaust gases under the vehicle, make certain that no part of the exhaust system intrudes into the departure angle or approach angle of the vehicle, unless it is protected by a skid bar or other protection device. The shaded areas in Figure 6-4 illustrate acceptable tailpipe termination locations.

**▲WARNING** *Exhaust gas presents the hazard of severe personal injury or death. Do not mount any portion of the exhaust system into the approach or departure angle unless it is adequately protected. Use only Onan-specified exhaust equipment with the generator set. Use a sufficient number of hangers to prevent dislocation of the system.*

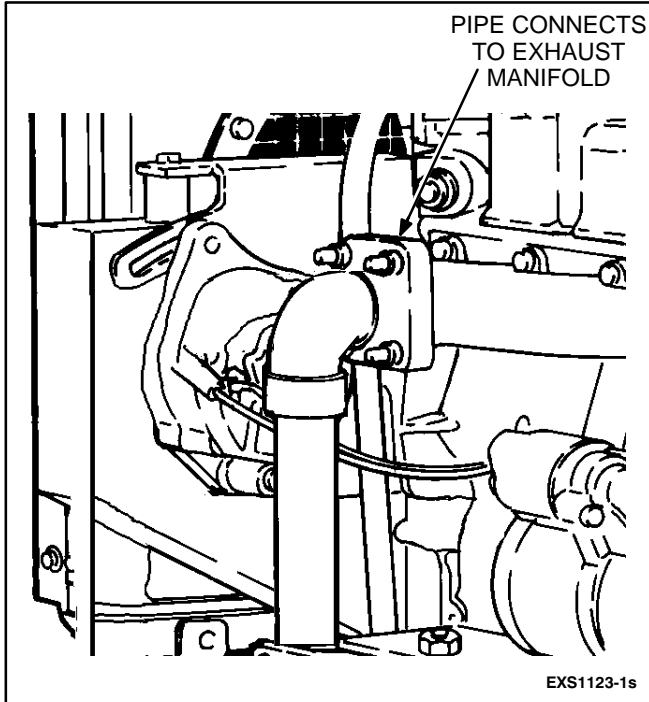

FIGURE 6-1. EXHAUST PIPE CONNECTION

### TAILPIPE RECOMMENDATIONS

An exhaust tailpipe is not supplied with the generator set because length requirements vary between vehicle manufacturers. Refer to the following recommendations for information and safety considerations.

Use 1-1/2 inch (38.1 mm) I.D. 18 gauge rigid steel tubing for tailpipe. This size is sufficient for 20 foot (6 m) lengths. Greater lengths may require a larger pipe size to prevent excessive back pressure.

The maximum allowable back pressure measured at the exhaust manifold is two inches (50 mm) mercury. Back pressure readings higher than this might affect engine performance.

**⚠WARNING** *Exhaust gas presents the hazard of severe personal injury or death. Do not use flexible exhaust tailpipe, because it can leak or break from road shock or vibration. Do not terminate the exhaust system under the vehicle. Direct exhaust gases away from any window, door, or compartment openings. Do not operate the generator set without an exhaust tailpipe.*

Use a U-bolt type automotive muffler clamp to connect exhaust tailpipe to muffler outlet. It is sug-

gested that two slots be cut into the tailpipe wherever a clamp joint is made, to ensure adequate clamping. See Figure 6-2.

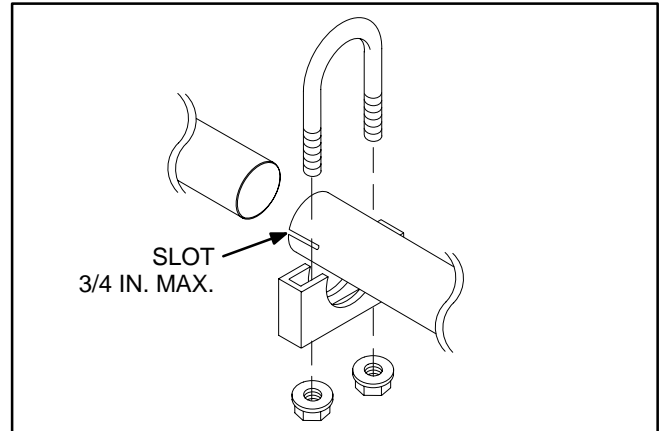

FIGURE 6-2. EXHAUST PIPE SUPPORT

If the tailpipe extends beyond 1-1/2 foot (0.46 m) from the generator set, attach a flexible automotive tailpipe hanger for additional support. Also use an additional flexible automotive type tailpipe hanger every 2 to 3 feet (0.6 to 0.9 m) of tailpipe run. See Figure 6-3.

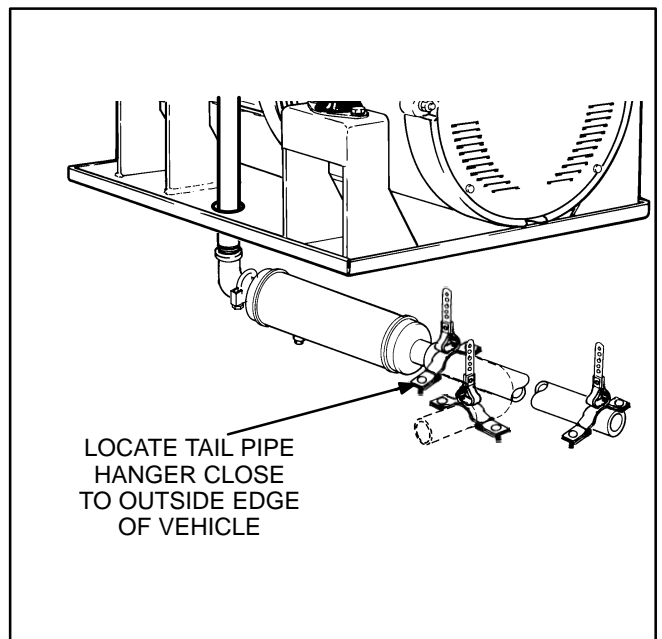
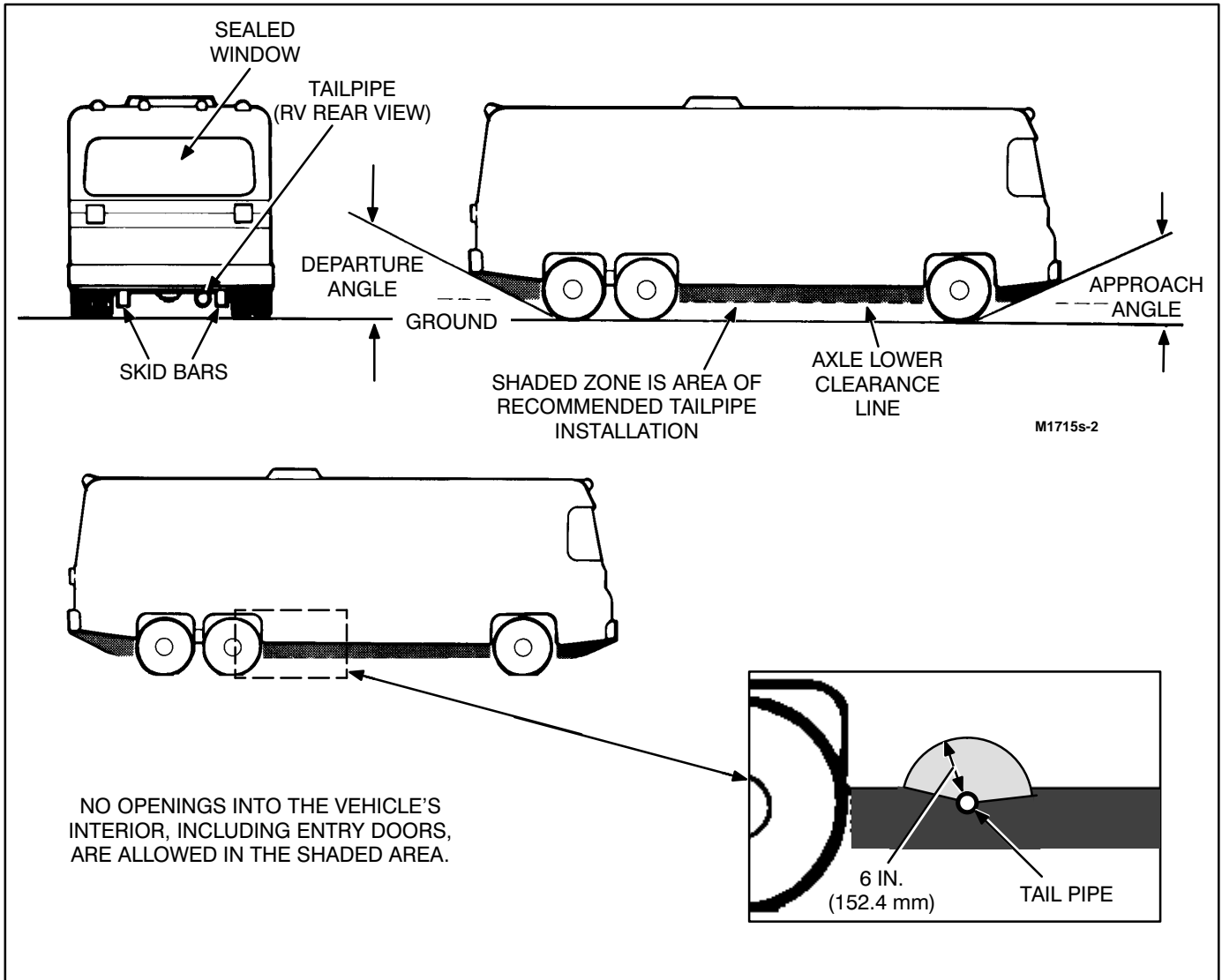

FIGURE 6-3. EXHAUST PIPE SUPPORT



**FIGURE 6-4. TAILPIPE INSTALLATION**

Support the exhaust system at or near the perimeter of the vehicle to prevent the pipe from being damaged and pushed up under the vehicle skirt. Attach hangers to steel framework, not wood or other floor materials. Protect the tailpipe by locating it in the shaded area in Figure 6-4. Extend the pipe at least one inch outside the vehicle as shown in Figure 6-5.

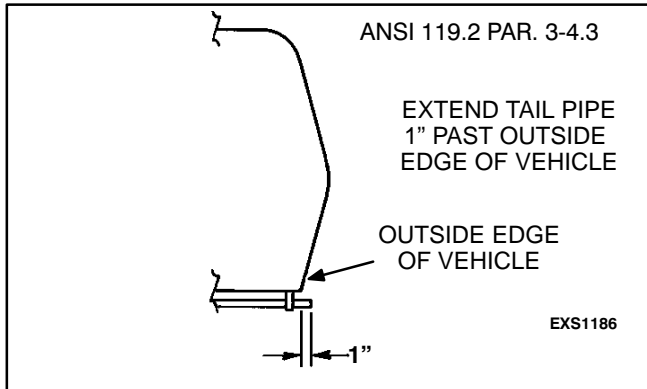

FIGURE 6-5. TAIL PIPE EXTENSION BEYOND VEHICLE

**CAUTION** Excessive exhaust back pressure can cause engine damage. If a tailpipe deflector is used, make sure it is large enough to prevent back pressure.

**CAUTION** Water vapor can cause engine damage. Do not connect the generator set exhaust to the vehicle exhaust system, because water vapor from one engine can damage the other.

The following procedure refers to the exhaust installation drawing in Figure 6-3.

1. The downpipe plumbing from the engine exhaust manifold should be completed before the unit is set in place and secured.
2. Install elbow on downpipe, then turn muffler onto the elbow. The muffler cleanout plug must face downward.
3. Attach tailpipe to muffler with a U-bolt type exhaust system clamp and hanger. Use an automotive tailpipe hanger for additional support at the perimeter of the vehicle.

**CAUTION** Angular mounting of muffler and tailpipe hanger brackets can result in exhaust system damage. Properly mounted hanger brackets will absorb much road shock vibration and prolong the use of exhaust system components. Mount muffler and tailpipe hanger brackets directly above the component supported, not at an angle. Do not twist the rubber sections of any hangers.



# 7. Cooling System

## COOLANT RECOVERY TANK

A coolant recovery tank should be installed with each generator set. Figures 7-1 and 7-2 illustrate cooling system components.

Use the bracket as a template to locate mounting holes. Allow a minimum of 2 inches (51 mm) from the top of the tank to any upper structure so the tank can be lifted off the bracket for servicing and filling. Mount with two 5/16 inch (8 mm) bolts.

Use a length of hose from the kit between the radiator overflow and the dip-tube connector on the re-

covery tank. This hose is heavier and resists collapse from vacuum. The original hose may be used on the overflow side to the drain. Allow sufficient hose lengths so the tank can be easily removed from the bracket to add coolant.

**NOTE: These instructions only provide an outline of recovery tank installation. Refer to recovery tank kit instructions for full details of installation.**

Engine coolant is at proper level when the recovery tank level is between Full and Low (engine cold).

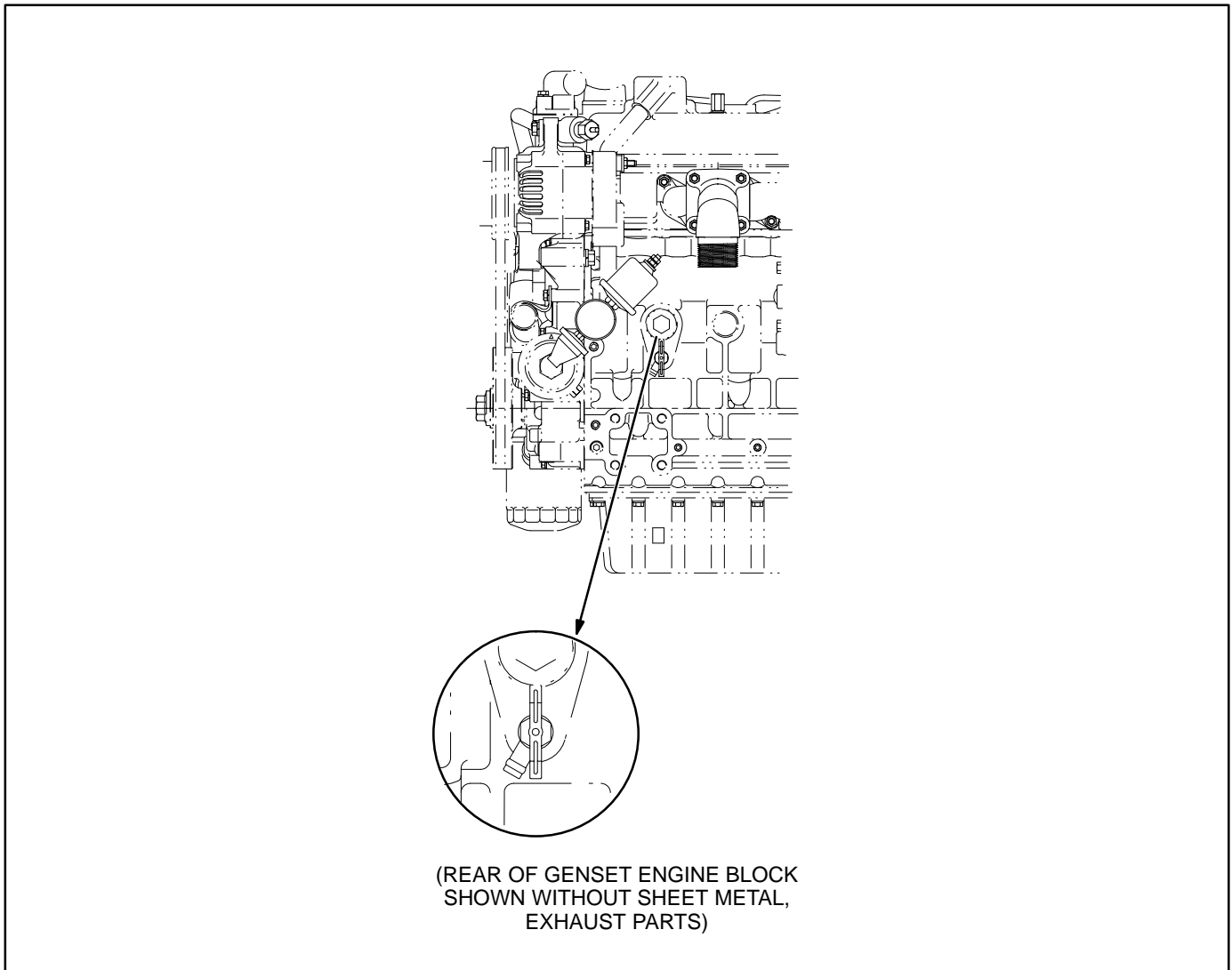
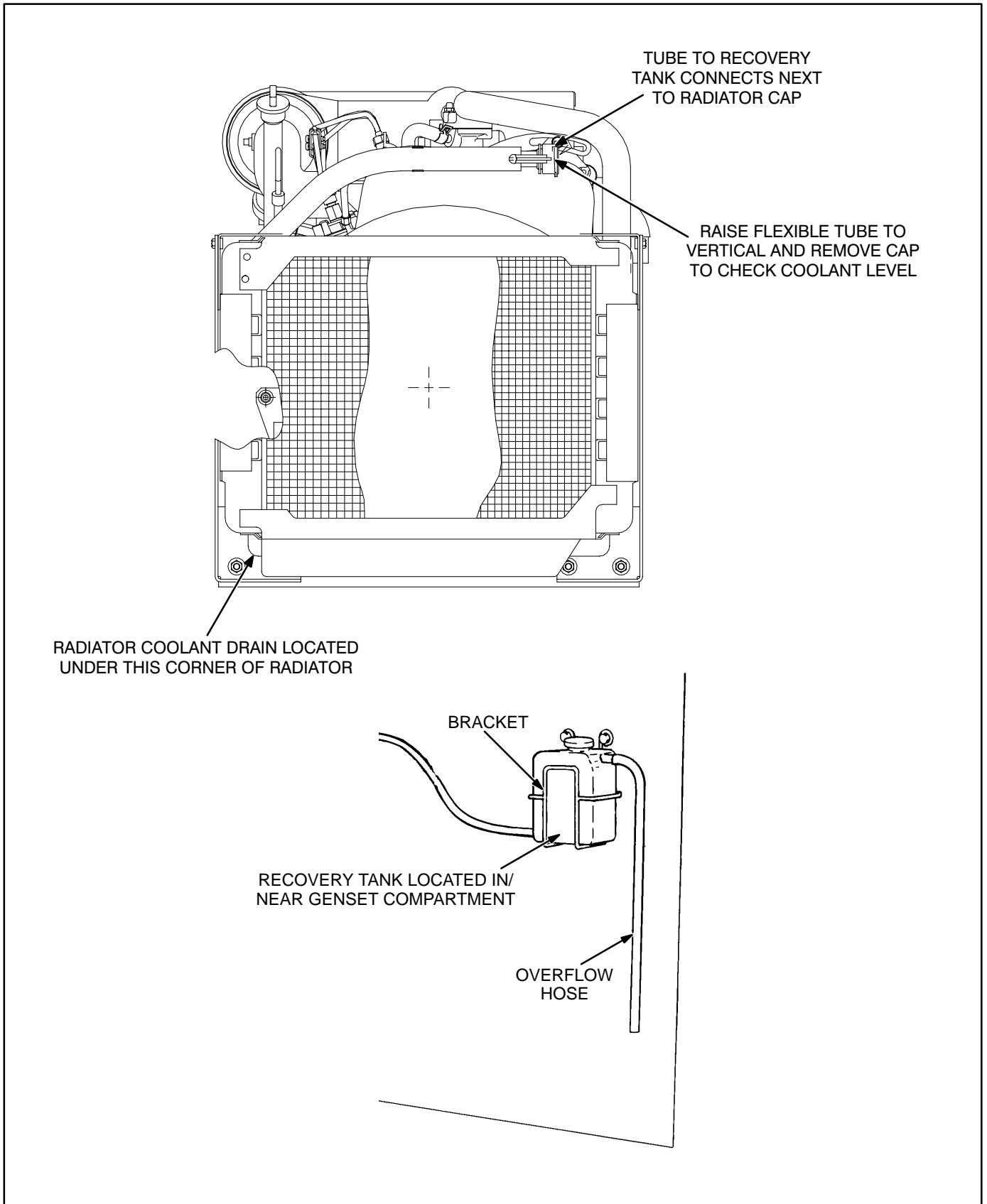

FIGURE 7-1. CYLINDER BLOCK COOLANT DRAIN





**FIGURE 7-2. COOLING SYSTEM COMPONENTS**

# 8. Fuel System

---

## GENERAL

This section describes fuel system installations for commercial and recreational vehicles.

**⚠WARNING** *Fuel presents the hazard of fire or explosion that can result in severe personal injury or death. Do not smoke or allow any flame, spark, pilot light, arc-producing equipment or switch on other ignition sources around fuel or fuel components, or in the installation area or areas sharing ventilation. Keep a type ABC fire extinguisher nearby. The ventilation system must provide a constant flow of air to expel any accumulation of fuel vapor while the vehicle is in transit. Compartments must be vapor-tight to the vehicle interior to prevent any fumes from entering these areas.*

## FUEL SYSTEM

### Fuel System Provisions

On some vehicles, the generator set can share the vehicle fuel supply tank with the vehicle engine. Connection to the vehicle fuel tank must be made according to the chassis (vehicle) manufacturer's detailed instructions. See *Fuel Line Installation*, in this section.

Onan recommends a separate fuel pickup tube or a separate fuel tank. Connection with the vehicle fuel line is not recommended; this may restrict flow to the generator set.

Onan recommends installing an in-line manual fuel shutoff valve, to close the fuel line when the set is removed for service.

### Recommended Fuel

Use ASTM 2-D (no. 2 Diesel) or ASTM 1-D (No. 1 Diesel) fuel with a minimum Cetane number of 45. Number 2 diesel fuel gives the best economy and performance under most conditions. Use number 1 diesel fuel when ambient temperatures are below 32° F (0° C), and during long periods of light engine load.

Use low sulfur content fuel which has a cloud point at least 10 degrees below the lowest expected fuel temperature. (Cloud point is the temperature at which wax crystals begin to form in diesel fuel.)

**⚠WARNING** *Fuel presents the hazard of fire or explosion that can cause severe personal injury or death. Never fill the fuel tank when the engine is hot or is running. Do not permit any flame, spark, pilot light, cigarette or other ignition source near the fuel system.*

### Fuel Consumption

Generator set fuel consumption varies with electrical load. Refer to the *Specifications* section for approximate fuel consumption at no load, half load, and full load.

### Fuel Line Installation

Vehicle fuel systems operate at a specified fuel pressure. For this reason, do not change or remove any parts of the fuel system without the approval of the vehicle manufacturer. Check the filler cap to make sure that the pressure vacuum relief valve functions properly: replace it if necessary.

If a separate connection is not supplied for the generator, add a second fuel pickup in the tank. This pickup should not extend below the bottom 1/4 of the tank, so the vehicle will run after the generator runs out of fuel.

Do not tee off the vehicle fuel pickup line. This may cause the generator set or the vehicle engine to run poorly. Consult the vehicle manufacturer for information on shared fuel supplies. Unauthorized fuel system modifications can cause dangerous operating conditions.

**⚠CAUTION** *Never use galvanized or copper fuel lines, fittings or fuel tanks with diesel fuel systems. Condensation in the tank and lines combines with the sulfur in diesel fuel to produce sulfuric acid. The molecular structure of the copper or galvanized lines or tanks reacts with the acid and contaminates the fuel.*

**⚠CAUTION** *The generator set could starve for fuel when the vehicle is operated at highway speeds if its fuel line is connected to the main fuel line with a tee. The generator set fuel pump has neither the capacity nor the power to overcome the draw of the vehicle engine fuel pump. For this reason, use a separate fuel line to the generator set, or use a separate fuel tank.*

Install an approved flexible non-metallic and non-organic fuel line between the vehicle fuel system and the generator set to absorb vibration. Flexible line must be long enough to prevent binding, stretching or breaking during set movement.

Connect the fuel supply and return lines to the generator set fuel pump using 1/4 IN. hose as shown in Figures 1-1 and 4-3.

Onan recommends seamless steel tubing and flared connections for long runs between the fuel tank and the flexible connector to the generator set.

Run fuel lines at the same height as the top level of the tank, to a point as close to the engine as possible. This reduces the danger of fuel siphoning out of the tank if the line should break.

Keep fuel lines away from hot engine or exhaust areas, to reduce the chance of vapor lock. Fuel lines should be accessible and protected from damage. Use metal straps without sharp edges to secure fuel lines. Do not run fuel lines where they may contact sharp or rough surfaces, or where they may be kinked, pinched, chafed, or struck.

### Fuel Line Connection

**⚠WARNING** *Fuel presents the hazard of fire or explosion that can result in severe personal injury or death. Do not smoke or allow any cigarette flame, spark, pilot light, arc-producing equipment or switch on other ignition sources near fuel or in the installation area or area sharing ventilation. Read the important safety precautions in the Fuel Systems section.*

**⚠WARNING** *Diesel fuel can be accidentally ignited by electrical sparks, presenting the hazard of fire or explosion, which can result in severe personal injury or death. For this reason, when installing the generator set:*

- Do not tie electrical wiring to fuel lines.
- Do not run electrical lines and fuel lines through the same compartment openings.
- Keep electrical and fuel lines as far apart as possible.
- Place a physical barrier between fuel lines and electrical lines wherever possible.
- If electrical and fuel lines must pass through the same compartment opening,

*make certain that they are physically separated by running them through individual channels, or by passing each line through a separate piece of tubing.*

7. Route fuel line separate from electrical wires or separate them with conduit or other sheathing.

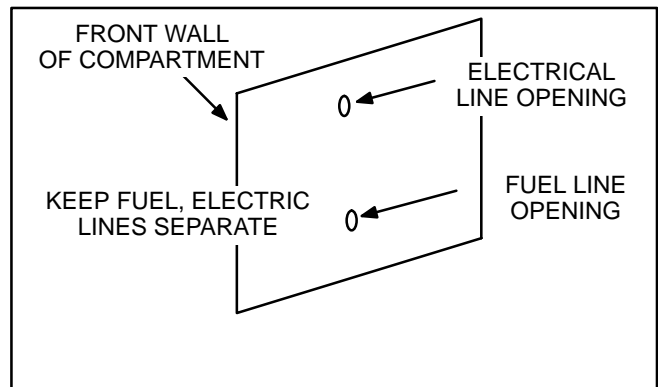

**FIGURE 8-1. FUEL AND ELECTRIC LINES**

8. Use fuel hose fittings for fuel tank pickup line (to fuel pump) and return line (from injectors). Use protective sleeving over frame rails. Protect holes with rubber grommets. Secure fuel line every 18 inches. Connect the fuel lines to bulkhead connectors. Do not “tee” into existing fuel lines used for vehicle propulsion engine operation. Doing this may restrict fuel delivery to the generator set.

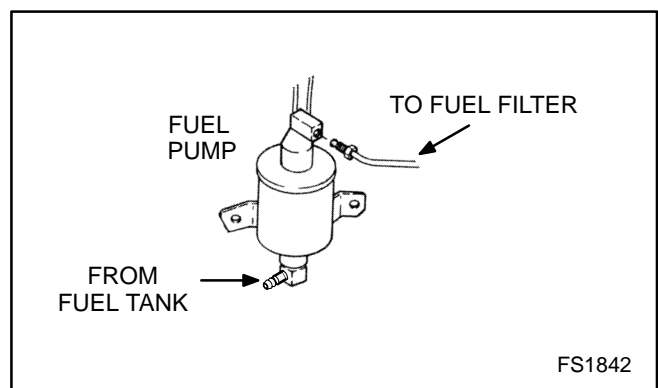

**FIGURE 8-2. FUEL LINE CONNECTION**

9. Connect the fuel lines to bulkhead connectors at the compartment, or protect them where they leave the compartment. Direction of fuel tank fittings must be adjusted during connection of fuel lines to prevent kinks or sharp bends.

# 9. Electrical Connections

## GENERAL

Installing the generator set electrical system includes connecting the load and connecting the battery. Always connect the battery last to avoid accidental starting of the unit during installation.

**⚠WARNING** *Accidental starting of the generator set during installation can cause severe personal injury or death. Do not connect the starting battery until instructed to later in this section.*

Wiring must be protected from sharp edges (screw heads, burrs, fins, moving parts), hot engine parts, exhaust system, fuel system, or any other objects that might damage the insulation.

The wiring must meet all applicable electrical codes. Have a qualified electrician install and inspect the wiring. All remote controls and switches

must be vibration-proof and securely mounted to prevent accidental closing or opening when the vehicle is moving.

## CONDUIT

Route load conductors from the generator set control to the junction box in approved flexible conduit. See Figure 9-1. Make sufficient slack in conduit to allow the unit free movement and for maintenance.

Be sure all openings made through the compartment for conduit and wiring and into the coach interior are sealed and vapor-tight. Seal wiring within the conduit if conduit terminates in the coach.

**⚠WARNING** *Inhalation of exhaust gases can cause severe personal injury or death. Seal all openings into the vehicle interior to prevent the entrance of exhaust gases.*

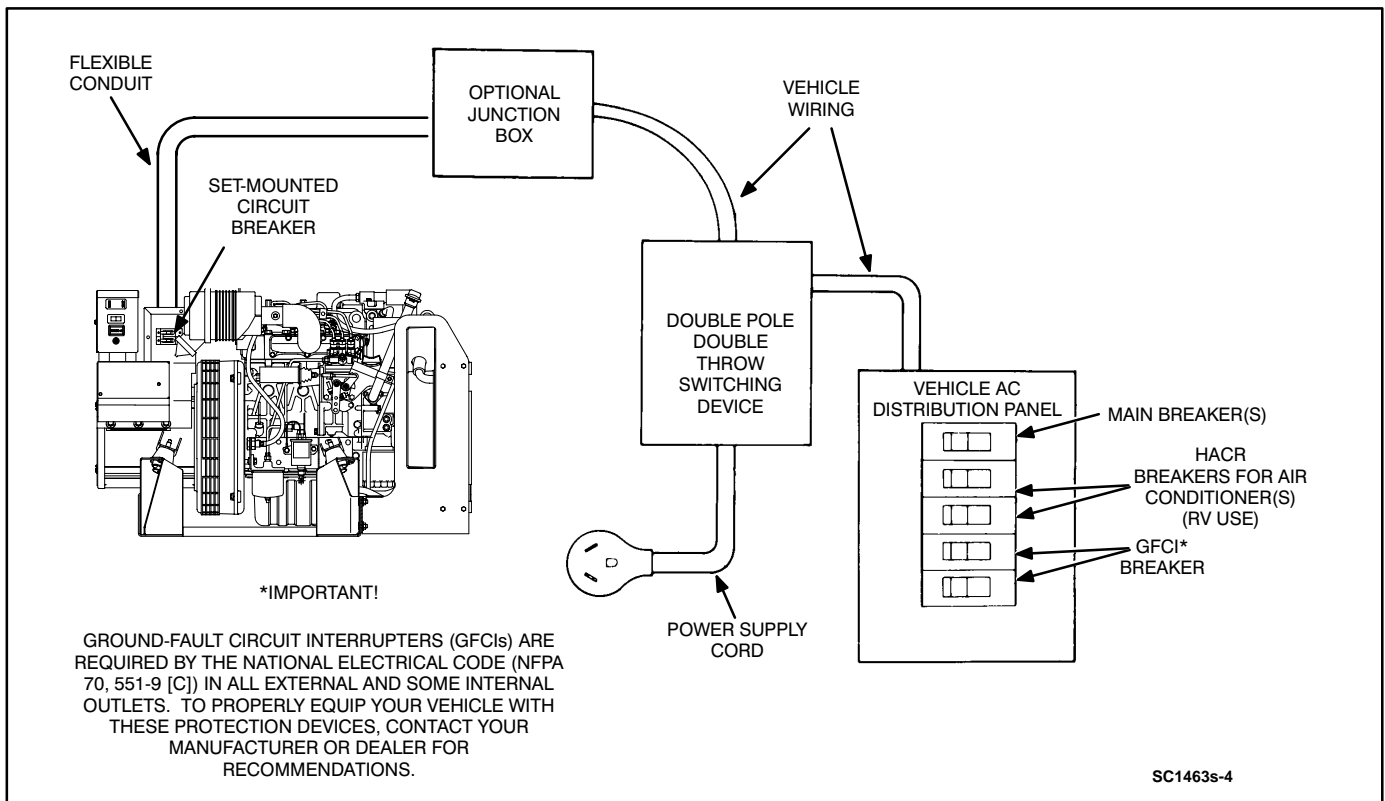

FIGURE 9-1. TYPICAL POWER SWITCHING DEVICE

## WIRING DISCONNECT

If the vehicle is equipped for a 30 amp 120 volt “shore power” (originating outside the vehicle) power system, a double-pole double-throw switching device must be used as a disconnecting device, so that the outside power source conductors cannot be connected to the generator set.

If the vehicle is equipped for a 50 amp 120/240 volt “shore power” (originating outside the vehicle) power system, a three-pole double-throw switching device must be used as a disconnecting device, so that the outside power source conductors cannot be connected to the generator set.

Never remove the grounding pin from power supply assemblies. Incorrect or no ground can cause the vehicle to be electrically “hot” and result in shock or electrocution.

**⚠WARNING** *Contact with electrically “hot” equipment can result in severe personal injury or death. It is extremely important that bonding and equipment grounding be properly done. All metallic parts which could become energized under abnormal conditions must be properly grounded.*

## LINE CIRCUIT BREAKERS

The AC circuit breaker or breakers provide short circuit and overload protection for the vehicle wiring and the generator. Circuit breaker type and configuration depend on the model. Circuit breakers are mounted on the side of the control box, or in some cases, elsewhere in the vehicle.

## LOAD CONNECTIONS

The generator output voltage(s) and maximum current rating(s) are specified on the generator nameplate. Line-to-neutral voltage is always the lower voltage shown on the nameplate and line-to-line voltage is the higher rating. Refer to Figures 9-2, 11-2 and 11-3 for AC output and generator reconnection diagrams.

## Connecting the Load

A 3/4 IN. water-tight connector is supplied. Reducer washers can be used to convert to a connector for 1/2 IN. conduit.

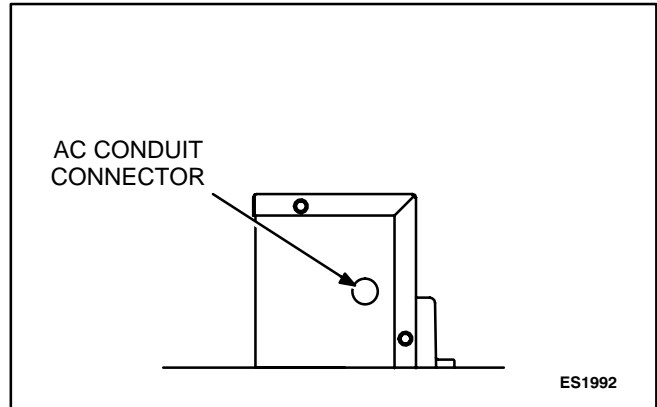

FIGURE 9-2. AC CONDUIT CONNECTION

Install the generator output conductors in approved flexible conduit. Cut conduit to desired length, leaving a minimum of 8” extra wire in the junction box for making connections to the load. Route conduit so movement of set is not interfered with. Leave extra conduit if the generator set is intended to slide out for maintenance.

Load wiring must be appropriately sized and insulated for the specified current rating. Grounding procedure must comply with codes.

Refer to the National Electrical Code, NFPA 70, for proper sizing and types of wiring.

**⚠WARNING** *Improper wiring can result in fire and severe personal injury or death. Do not allow contact between electrical wiring and the fuel line.*

**⚠WARNING** *Electrical shock can result in severe personal injury or death. Properly applied and maintained ground fault interrupters can afford additional protection against the hazard of electrical shock. Equip the vehicle with adequate ground fault protection devices to meet the National Electrical Code Code NFPA 70, 551-9 (c).*

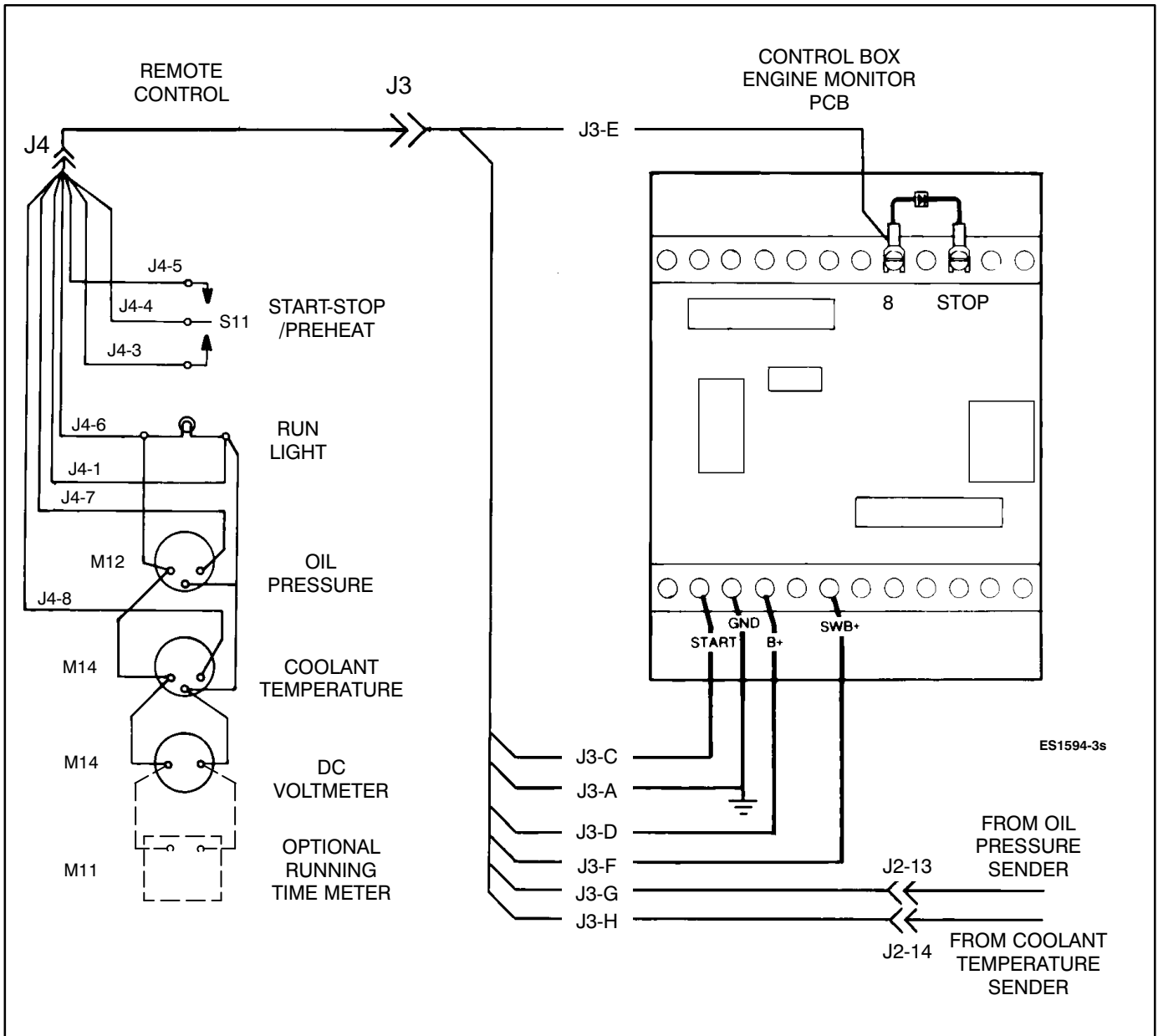

**FIGURE 9-3. REMOTE CONTROL CONNECTIONS**



## REMOTE CONTROL CONNECTIONS

Provision is made for addition of remote starting and stopping of the generator set. A ten-pin remote connector (J3) mounted on the control box connects the harness assembly to connector J4 on the remote control assembly. Onan has several remote control kits complete with installation instructions. Also available are complete harness assemblies with connectors. Call the Onan dealer or distributor for assistance in securing these items.

The wiring diagram in Figure 9-3 is furnished so a harness can be fabricated if desired. Use 18 AWG wire. The electrical code does not allow the remote control harness/wiring to be routed through the same conduit as the AC load wiring. Follow all national electrical codes and any local codes that may apply.

Be sure to seal all openings made for wiring so exhaust or fuel vapors cannot enter the living quarters or work area. Conduit must be sealed internally at the end where it terminates within the junction box or panel board.

**⚠WARNING** *Inhalation of exhaust gas or ignition of fuel vapor can cause severe personal injury or death. Be sure to vapor-seal flexible metal conduit and all openings made during installation of the generator set with a silicone/rubber based sealant.*

## STARTING BATTERY

The generator set must have sufficient cranking power to the starter under various operating conditions. Choose a battery and cables that are appropriate for the application and then devise an adequate battery compartment.

### Battery and Cable Selection

The HDKAL/HDKAQ/HDKAR generator set requires a 12-volt battery with a rating of 425 cold cranking amps. If the temperature is expected to be below 32° F (0° C), the battery rating should be at least 625 CCA). A larger capacity battery may be desirable if it is also used to power other coach accessories. Onan does not recommend use of the vehicle starting battery for operation of the generator set. Doing so might discharge the battery under some operating conditions.

The starter draws 100 to 150 amperes of current at 72° F (22° C). The inrush current is 300 to 400 amperes.

For reliable cold weather starting, the voltage drop from the battery terminals to the starter terminal should not exceed 0.12 volts per 100 amperes of current. The starter motor draws (100) amperes at 12 VDC. Table 9-1 shows the recommended cable sizes for different cable lengths necessary for reliable cold weather starting to -20° F (-29° C).

**TABLE 9-1. CABLES FOR COLD WEATHER STARTING TO -20°F (-29°C)**

*CABLE LENGTH IN FEET (METERS)	CABLE SIZE
0-10 (0-3)	2**
11-15 (3-4.5)	0
16-20 (4.5-6.1)	000

\* Distance from battery to set.

\*\* #2 cable is acceptable up to 20 feet (6.1 m) for:  
- Operation in temperatures above 32° F (0° C).  
- Battery Ratings greater than 1000 CCA.

### Battery Compartment

House the battery in its own compartment, away from the generator set and any spark-producing device. The compartment must be properly ventilated with a minimum opening at the top and bottom of 1.7 in<sup>2</sup> (11 cm<sup>2</sup>) and in a location where leaks and accidental spills will not damage the generator set, fuel lines, and wiring.

**⚠WARNING** *Fire or explosion hazards can cause severe personal injury or death. Be sure to mount the battery in a separate compartment away from the generator set or other spark-producing device.*

### Battery Connections

Be sure the frame connection (major frame member, if possible) is sufficient to minimize resistance. Try to avoid connection at a weld or mechanical joint. For short distances, one negative battery cable can be used between set and battery rather than separate cables to chassis ground.

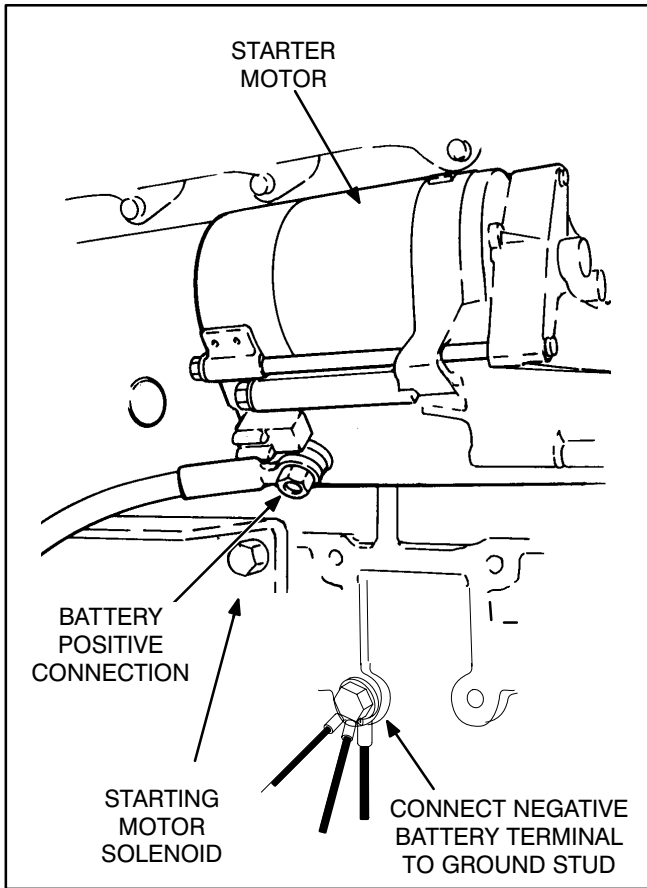

**FIGURE 9-4. BATTERY CONNECTIONS**

The battery positive (+) terminal connects to the start solenoid (Figure 9-4). Connect negative battery cable last. Use the same size cable to connect battery negative terminal to ground as used for battery positive. Connect battery negative (-) to the ground bolt just below the starter connection. Do not attempt to connect the battery negative to any other part of the genset. Be sure terminal connections are clean and tight.

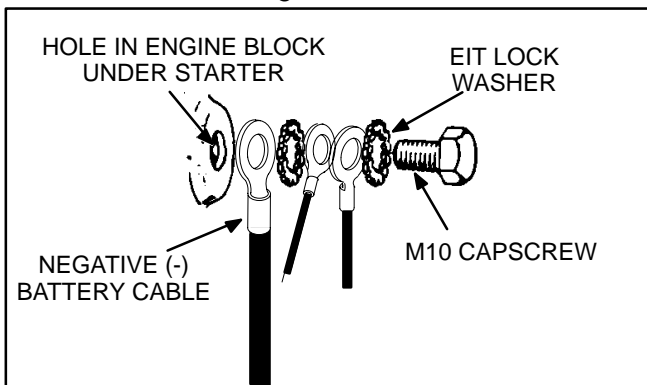
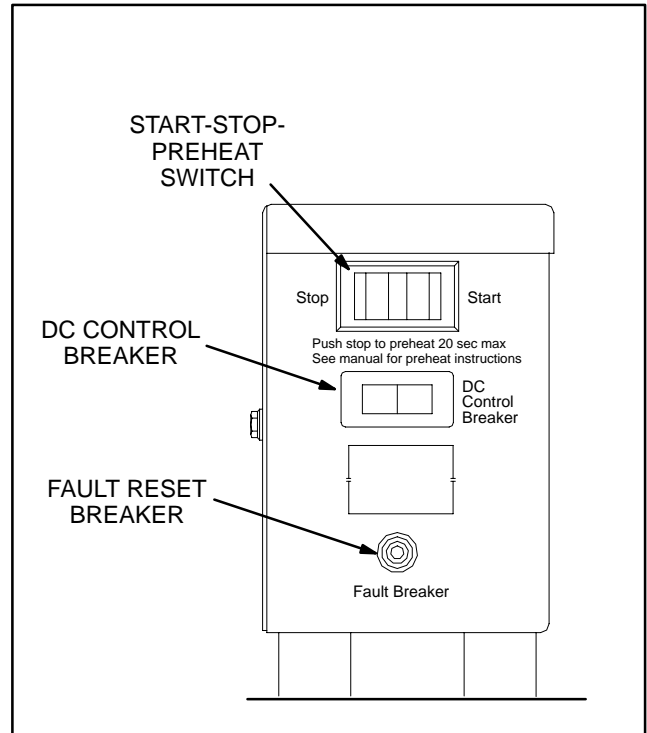

**FIGURE 9-5. BATT NEGATIVE (-) CONNECTION**

**⚠WARNING** Ignition of explosive battery gases can cause severe personal injury. Do not smoke while servicing batteries.

**⚠WARNING** Sparks can ignite battery gases and result in an explosion and severe personal injury. Do not disconnect battery cables while generator set is cranking or running.

The belt-driven battery charge alternator has a maximum output rating of 30 amps. The actual output amperage depends on the battery state-of-charge and any load that may be connected to the battery.



**FIGURE 9-6. DC CONTROL BOX FRONT PANEL**

### REMOTE INSTALLATION OF GENSET CONTROL BOXES

If the DC control box is not accessible with the generator set installed, it may be remotely mounted. Extension harnesses are available.

### DC Control Box Location and Mounting

Locate the control box in an area that will not be contaminated by grease, oil, dust or dirt. A low-vibration area with maximum accessibility is the best location.



---

The control box must be mounted in an area with a temperature less than 160° F (71.1° C). Higher temperatures may damage the control.

**⚠ CAUTION** *Failure to mount the control box in an environment with a temperature less than 160° F (71.1° C) may cause equipment damage or failure.*

Remove the DC control box cover and unscrew the bolts from the four vibration isolators (rubber mounting feet) that support the control box. Remove the control box and isolators from the studs on the mounting surface. Drill holes of the appropriate size and place the box into position. Make certain that there is enough room to insert and remove the wiring harness connector plugs in the back of the control box (see Figure 9-7). Make certain that the genset controls are easily viewed and readily accessible to the operator.

It is not mandatory that the vibration isolators be used. In a low-vibration environment, the genset may be mounted directly to a surface without using the isolators.

However, if using the isolators, note the following:

**The toothed washers (provided) must be mounted under the vibration isolators as shown in Figure 9-7.** These washers, when mounted correctly as shown in the illustration, will prevent the vibration isolators from rotating. When the isolators rotate under pressure, they can deteriorate rapidly.

**⚠ CAUTION** *If mounting the control box with the rubber vibration isolators, use the toothed washers to make certain that the isolators do not rotate. Failure to follow this guideline may promote deterioration of the control box mounting, and subsequent equipment damage.*

## AC Control Box Location and Mounting

If the AC control box is not accessible with the generator set installed, it may be necessary to remotely mount the circuit breakers. In this case, the genset mounted circuit breakers should be removed and new circuit breakers installed in an accessible location. Onan has remote circuit breaker boxes available. Refer to load connections earlier in this section for complete information.

## Electrical Connection to Generator Set

**NOTE: If the control box is mounted more than a few feet from its original position, extension harnesses are needed. These are available in several lengths. Contact your Onan dealer or distributor.**

The generator set is shipped with two harnesses. After mounting the control box, plug the harness connectors into the control box. The J2 harness (see Figure 9-7) has the largest connector. This harness conducts control and annunciation functions to and from the set. The J1 harness has a smaller four-conductor connector. This provides AC monitoring from the AC control box on the set.

Route the harnesses against the walls of the genset compartment, mounting them so that they are out of the way and will not interfere with genset operation. Make certain that the harnesses are kept away from sharp edges or heavy objects that could cut, fray, pinch or otherwise damage them. Neatly coil and store any excess harness length in a position where it is out of harm's way.

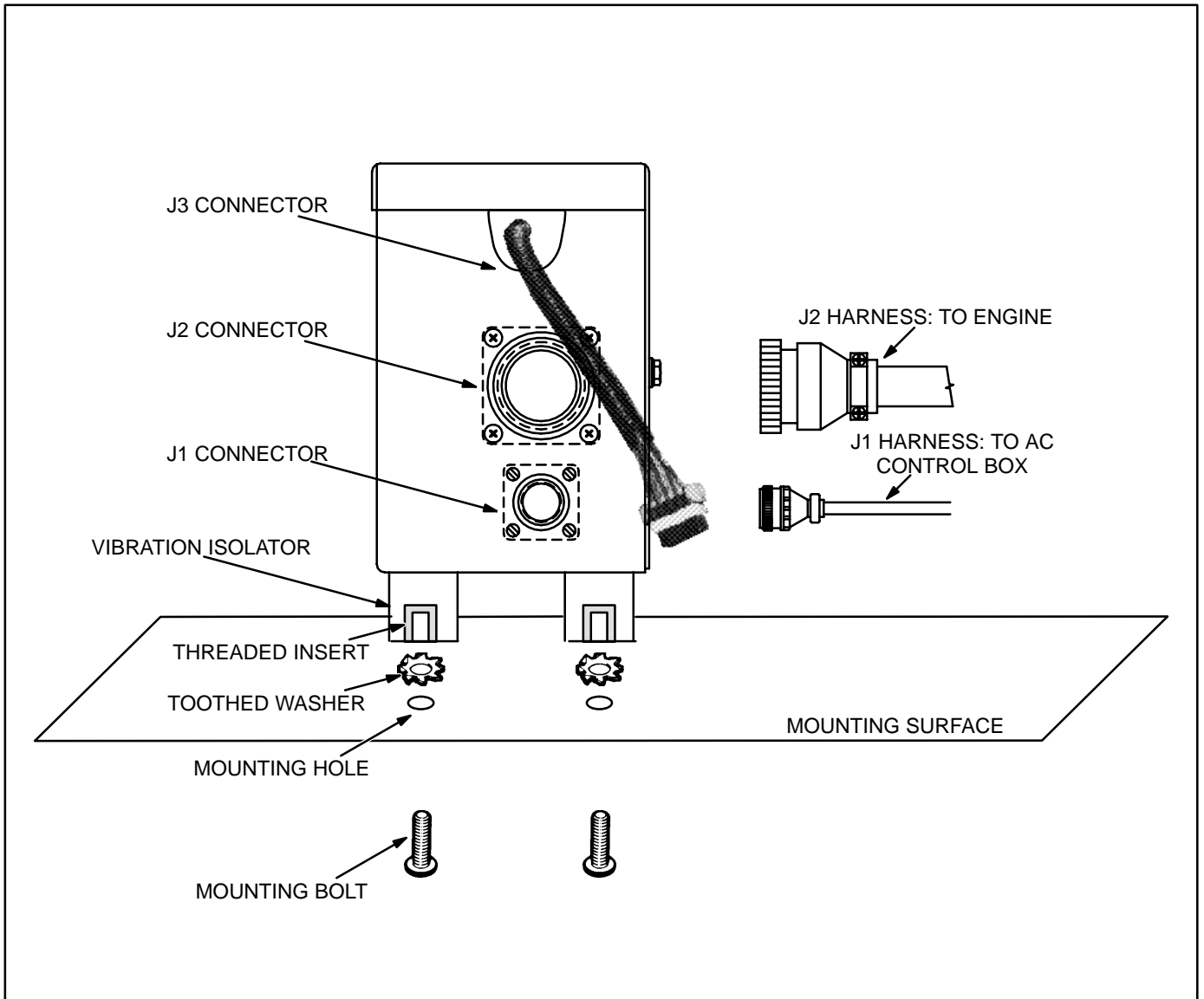

**FIGURE 9-7. REMOTE DC CONTROL BOX MOUNTING**

Blank Page

# 10. Initial Start and Checks

---

## INSTALLATION REVIEW

Before initial start up of the generator set, check (√) each of the following items. For a good installation, each answer must be **yes**: if not, that part of the installation should be reworked, or provision made to satisfy the requirement.

**⚠WARNING** *Incorrect installation, service, or parts replacement can result in severe personal injury, death, and/or equipment damage. Installing personnel must be qualified to perform electrical and mechanical component installations and service.*

- Is the compartment metal-lined and sealed around all edges?
- Are all fuel connections and hose clamps tight?
- Are fuel lines and electrical wires protected from chafing and damage and are they insulated from each other?
- Are wiring holes into the inside of coach (including the inside of AC conduit) sealed to prevent passage of exhaust gases?
- Are all electrical leads connected and protected, and is the conduit adequately supported?
- Are there openable windows, doors or storage compartments? Refer to the *Exhaust System* section for correct positioning of these components.
- Does the exhaust system extend beyond the perimeter of the vehicle a minimum of 1 inch (25 mm)?
- If the exhaust system is run into the angle of approach or departure (see Figure 6-1), is it protected from bottoming out by use of skid bars, rollers, etc.?
- Is the exhaust system secure and are all connections tight? Are all required exhaust clamps, hangers, and support straps in place per the *Exhaust System* section of this manual and the kit instructions?
- Are air inlet and exhaust openings clear and sufficiently sized (see *Mounting* section) for proper airflow?
- Is the generator set protected from direct road splash from vehicle wheels?
- Can the following routine maintenance items be performed through the vehicle access panel?
  - Change oil
  - Start/stop the unit
  - Change air filter
  - Access AC circuit breaker and control fuse
  - Access coolant fill and drain
- Is the oil level correct?
- Are the exhaust system, wiring, fuel lines and other components positioned so that they do not interfere with the free movement of the isolation system of the generator set?
- Is the coolant level correct?

---

**⚠WARNING**

**EXHAUST GAS IS DEADLY!**

*Exhaust gases contain carbon monoxide, an odorless and colorless gas. Carbon monoxide is poisonous and can cause unconsciousness and death. Symptoms of carbon monoxide poisoning can include:*

- *Dizziness*
- *Nausea*
- *Headache*
- *Weakness and Sleepiness*
- *Throbbing in Temples*
- *Muscular Twitching*
- *Vomiting*
- *Inability to Think Coherently*

***IF YOU OR ANYONE ELSE EXPERIENCE ANY OF THESE SYMPTOMS, GET OUT INTO THE FRESH AIR IMMEDIATELY. If symptoms persist, seek medical attention. Shut down the unit and do not operate until it has been inspected and repaired.***

***Never sleep in vehicle with the generator set running unless the vehicle interior is equipped with an operating carbon monoxide detector. Protection against carbon monoxide inhalation also includes proper exhaust system installation and visual and audible inspection of the complete exhaust system at the start of each generator set operation.***

1-RV

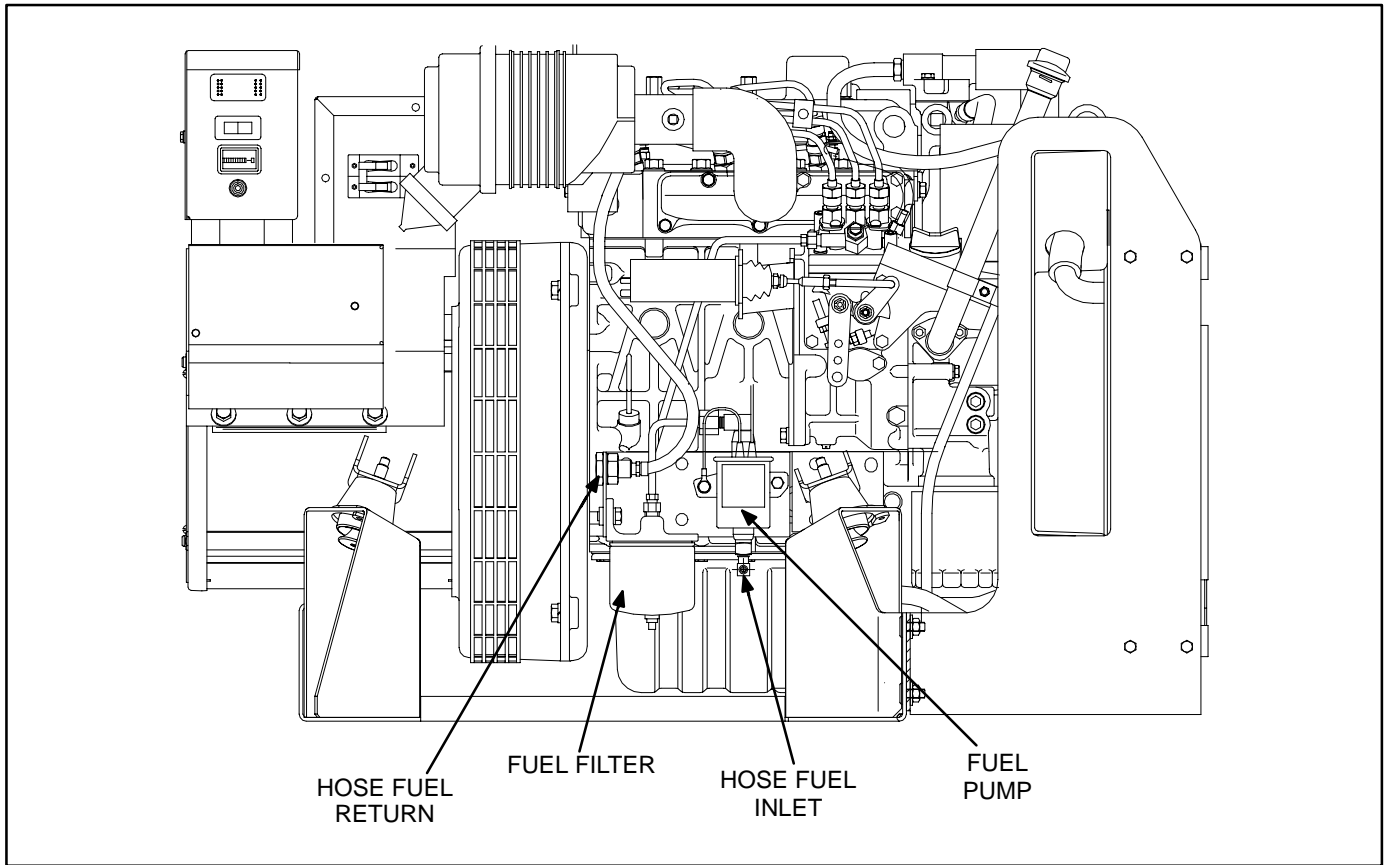

**FIGURE 10-1. FUEL SYSTEM**

### INITIAL STARTING AND CHECKS

**⚠WARNING** *Exhaust gas presents the hazard of severe personal injury or death. Do not operate the generator set inside any room or building.*

If none of the fuel line junctions have been loosened between the electric fuel pump and the injection pump, the fuel system should not need priming. However, if priming is necessary, it should be done according to the following procedure.

#### Priming the Fuel System

**⚠CAUTION** *Priming the fuel system should only be done by a skilled and experienced diesel technician. Incorrect priming could lead to equipment damage or faulty operation.*

1. Disconnect the negative (-) lead to the genset starting battery, to make certain that the generator set cannot be started.
2. Use clip leads to jumper B+ and ground to the electric fuel pump. Run the fuel pump for five to ten seconds until the air is purged from the low-pressure fuel system.
3. Reconnect the starting battery so that the generator set may be cranked.

---

If air still remains in the fuel system, further priming is necessary. **If further priming is necessary, consult a trained diesel technician or an authorized Onan service center.**

### Starting the Generator Set

1. Start the generator set by first holding the Start/Stop/Preheat switch on the engine control panel as described in the Operator's Manual. Then hold the switch in the Start position. The engine should start within a few seconds. If it doesn't start, refer to the Service Manual for troubleshooting.
2. Monitor the remote mounted engine control panel and note the oil pressure, coolant temperature, and battery charge voltage gauges (if equipped). Refer to the Operator's Manual for normal readings. At operating temperature, all readings should stay within the normal range.
3. Check the exhaust system for leaks, visually and audibly. Note the security of the exhaust

system supports. If any leaks are found, shut down the generator set immediately and repair.

**▲WARNING Exhaust gas is deadly. For this reason, shut down the generator set immediately if you discover an exhaust leak or exhaust component needing replacement. Do not use the generator set until you have the exhaust system repaired.**

4. Check the generator set for fuel, oil or coolant leaks. If any are found, shut down the generator set and repair leak before making any more checks.
5. Connect an accurate AC voltmeter and frequency meter across two line terminals. Apply load to the generator and check output voltage and frequency. Consult a trained Onan service technician if adjustment is necessary.

**▲WARNING Generator output presents a shock hazard which can result in severe personal injury or death. Use caution when measuring output voltage and frequency.**

# 11. Wiring Diagrams

---

The electrical schematics and wiring diagrams that apply to the generator set covered in this manual are listed below.

<b>WIRING DIAGRAM</b>	<b>DRAWING NO.</b>	<b>PAGE</b>
DC Control Assembly .....	612-6689 .....	11-2
AC Control Assembly (single-phase) .....	612-6637 .....	11-3



DC WIRING DIAGRAM

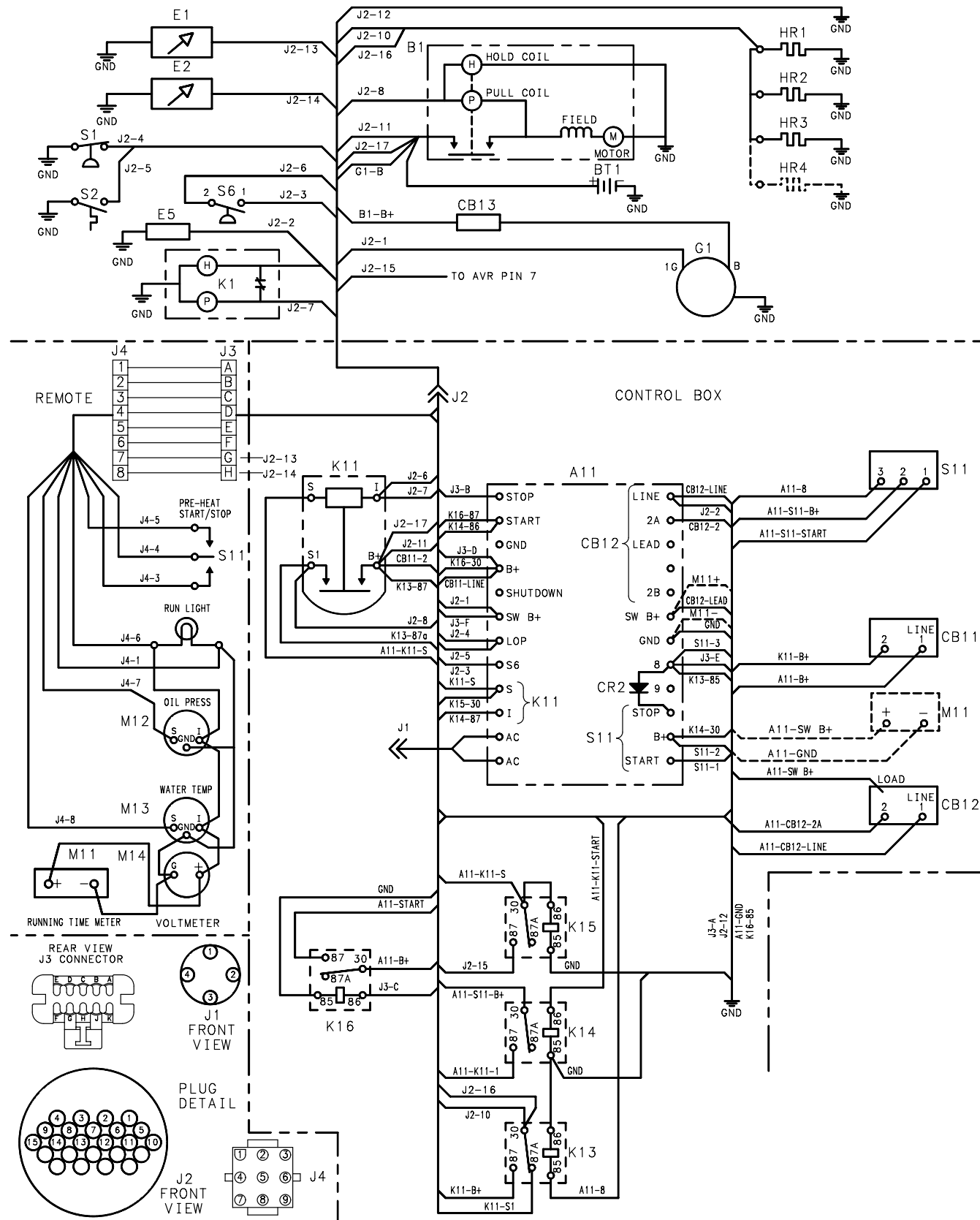

SCHEMATIC

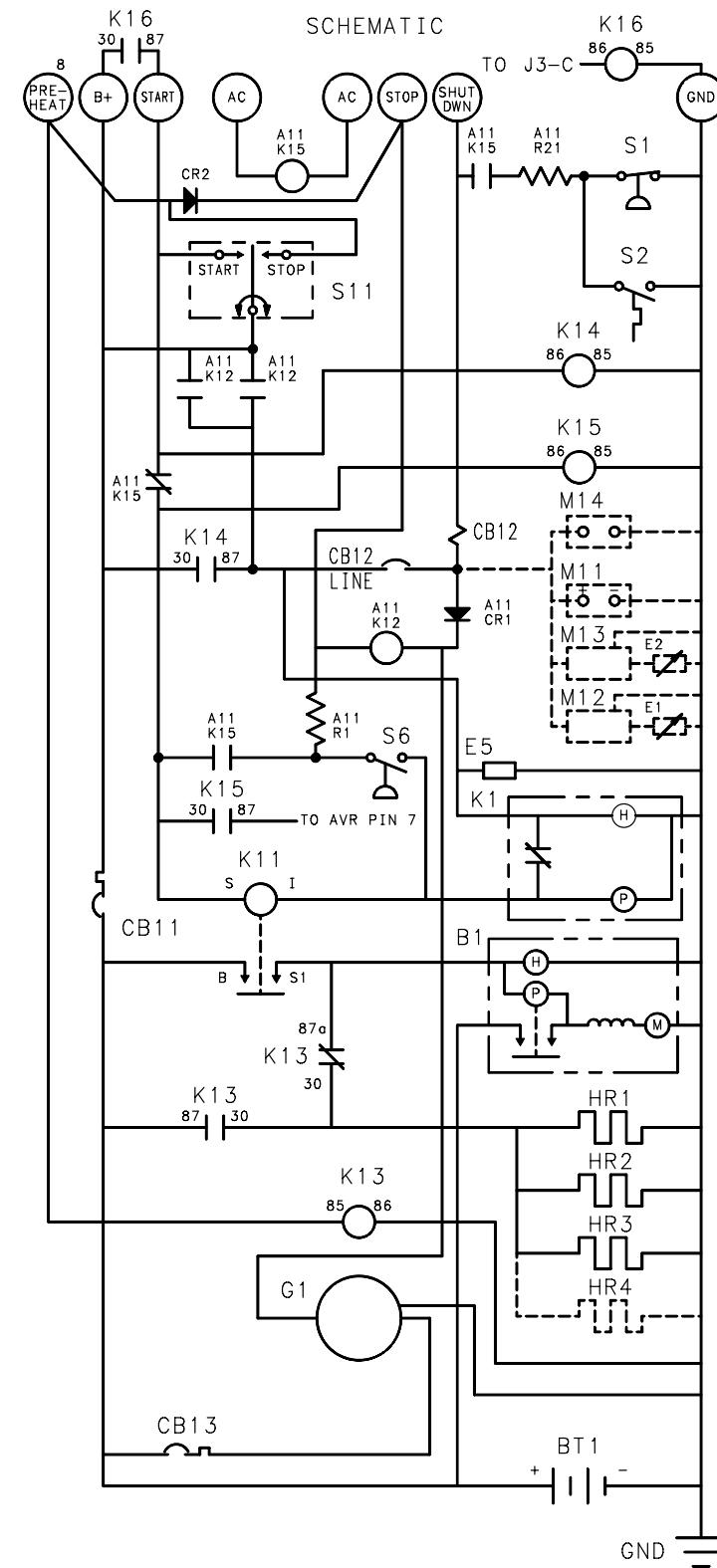

ENGINE PARTS LIST (FOR REF ONLY)			
B1		(1)	STARTER & SOLENOID
BT1		(1)	BATTERY (12V)
E1		(1)	SENDER-OIL PRESSURE
E2		(1)	SENDER-COOLANT TEMP
E5		(1)	FUEL PUMP-ELECTRIC
G1		(1)	ALTERNATOR
HR1-3,4		(3,4)	HEATER-GLOW PLUG
K1		(1)	SOLENOID-FUEL
S1		(1)	SWITCH-LOW OIL PRESSURE
S2		(1)	SWITCH-HIGH COOLANT TEMP
S6		(1)	SWITCH-CONTROL POWER LATCH
CONTROL BOX PARTS			
319-3049	D	(1)	CONTROL ASSY
338-3338	D	(1)	HARNES-ENG
A11	300-2604	D	(1) PCB ASSY-ENGINE MONITOR
CB11	320-1140	C	(1) CIRCUIT BREAKER (CONTROL)
CB12	320-1141	A	(1) CIRCUIT BREAKER (FAULT)
CB13	320-1658	B	(1) CIRCUIT BREAKER
J3-J4		REF	CONNECTOR-REMOTE
K11	307-1617	B	(1) RELAY-START SOLENOID(STARTER) (12V)
A11-K12		REF	RELAY-POWER
K13	307-1886	P	(1) RELAY-HEATER (12V)
K14	307-1886	P	(1) RELAY-FUEL SOLENOID
A11-K15		REF	RELAY-STARTER PROTECTION
K15	307-1886	P	(1) RELAY-
K16	307-1886	P	(1) RELAY-REMOTE START
A11-R1		REF	RESISTOR (K12)
A11-R2		REF	RESISTOR (LOP TIMING)
S11	308-0739	A	(1) SWITCH-START STOP

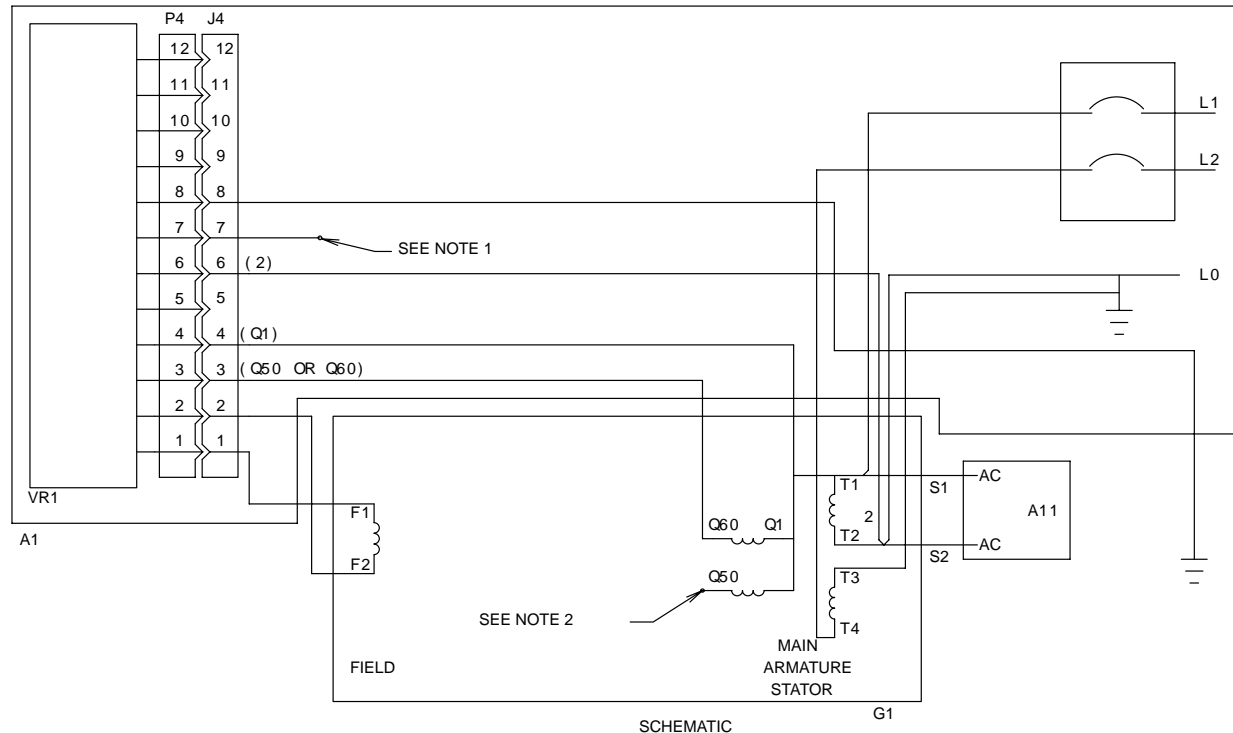

SCHMATIC G1  
 110/ 220V, 115/ 230V & 120/ 240V AS SHOWN  
 SEE RECONNECTI ON CHART FOR OTHER VOLTAGES

REF DES	PART NO	DWG SIZE	QTY	DESCRIPTION
1	---	--	1	WIRE HARNESS
2	---	--	1	LEAD (F1)
3	---	--	1	LEAD (F2)
G1	---	--	1	GENERATOR
VR1	---	--	1	VOLTAGE REG CAP AVR

- NOTE:
1. FROM J2-15 FOR FIELD FLASHING.
  2. QUADRATURE POWER CONNECTION Q60-60 HZ, Q50-50 HZ UNITS.
  3. AVR REFERENCE VOLTAGE.

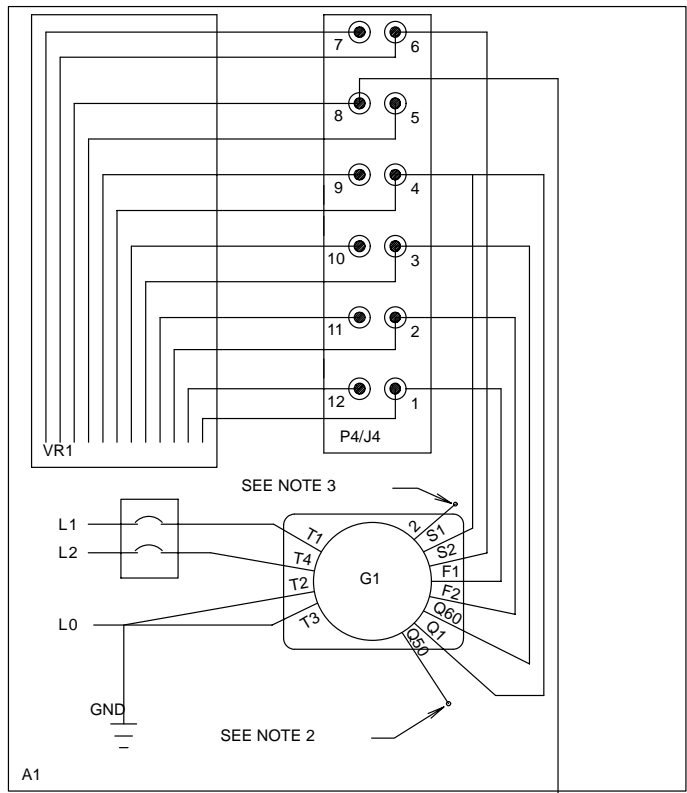

WIRING DIAGRAM  
 110/ 220V, 115/ 230V & 120/ 240V AS SHOWN  
 SEE RECONNECTI ON CHART FOR OTHER VOLTAGES

	A	B	C	HZ	CODE
VOLTAGE	100 120	200 240	100/ 200 120/ 240	60	J
	110 115	220 230	110/ 220 115/ 230	50	P
SCHEMATIC					
	GENERATOR RECONNECTION CHART				

**Onan**

Cummins Power Generation  
1400 73rd Avenue N.E.  
Minneapolis, MN 55432  
763-574-5000  
Fax: 763-528-7229

Cummins and Onan are registered trademarks of Cummins Inc.



Redistribution or publication of this document  
by any means, is strictly prohibited.